

ANGLE PIN HOUSING

ES Guía Regulable DE Schägstiftbuchse
IT Colonna Regolabile PT Guia Regulável FR Guidage de Verrouillage

GR



● Cad Insertion Point

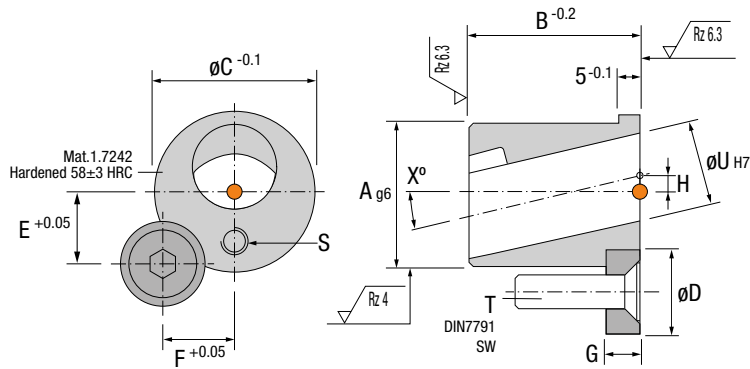

Ref.	A	B	C	D	E	F	G	H	S	T	U	X°	SW	
GR.182622-..	18	26	22	12	10.8	7.5	6	3.8	M5x5	M5x16	10	10	15	3
GR.222826-..	22	28	26	16	11	11	6	4	M6x6	M6x16	12	10	15	4
GR.283432-..	28	34	32	16	13	13	6	5	M6x6	M6x16	16	10	15	4
GR.344038-..	34	40	38	20	17	17	8	5.5	M8x6	M8x20	20	10	15	5
GR.424546-..	42	45	46	20	19.5	19.5	8	6	M8x6	M8x20	24	10	15	5
GR.465050-..	46	50	50	20	21	21	8	7	M8x6	M8x20	28	10	15	5

IMPORTANT !
Indicate the desired **X** dimension after the reference.
Indicar al final de la referencia, la cota **X** deseada.
Gewünschte **X** Dimension angeben, nach der Referenznr.
Indicare la quota **X** desiderata alla fine del codice.
Indique o dimensão **X** desejada depois da referência.
Préciser le début de référence et le compléter par la dimension **X** souhaitée.

Patented



ANGLE PIN

ES Guía Inclinada DE Schrägstift
IT Colonna Inclinata PT Guia Inclinada FR Doigt de Demoulage

GI

● Cad Insertion Point

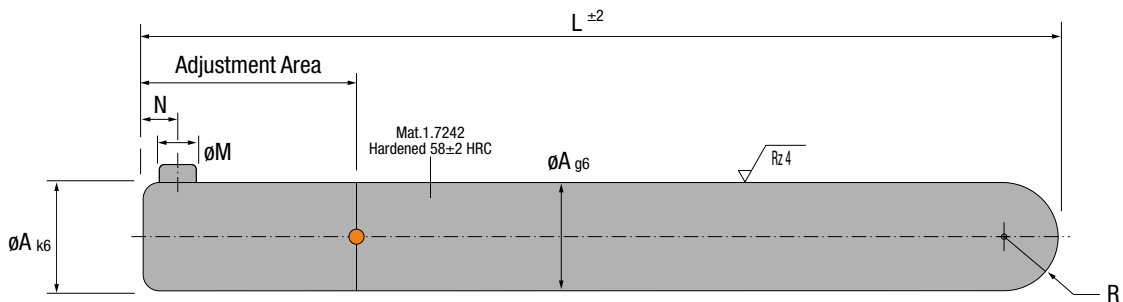

Ref.	A	Adjustment Area	M	N	L	R
Gi.010...	10	≈ 25	4	4	075 090 105	5
Gi.012...	12	≈ 30	4	4	095 110 130	6
Gi.016...	16	≈ 35	4	4	115 135 160	8
Gi.020...	20	≈ 40	6	6	140 165 190	10
Gi.024...	24	≈ 45	6	6	170 195 220	12
Gi.028...	28	≈ 50	6	6	200 225 250	14

IMPORTANT !
Indicate the desired **L** dimension after the reference.
Indicar al final de la referencia, la cota **L** deseada.
Gewünschte **L** Dimension angeben, nach der Referenznr.
Indicare la quota **L** desiderata alla fine del codice.
Indique o dimensão **L** desejada depois da referência.
Préciser le début de référence et le compléter par la dimension **L** souhaitée.

