

FIXED LIFTER BASE

ES Deslizamiento Fijo DE Gelenkstück für Schrägäuswerfer
IT Scorrimento Fisso PT Deslizamento Fixo FR Glissière Fixe



DF

● Cad Insertion Point

Ref.	A	B	C	D	E	F	H	T	SW
DF.061220	6	12	20	11.5	12	0.5	10	M4x12	3
DF.081220	8	12	20	11.5	12	0.5	10	M5x12	4
DF.101624	10	16	24	13.5	14	0.5	12	M6x16	5
DF.121624	12	16	24	13.5	14	1	12	M8x16	6
DF.162032	16	20	32	19	18	1.5	16	M8x25	6
DF.202538	20	25	38	21	21	1.5	19	M10x25	8
DF.253148	25	31	48	28	26	2	24	M12x35	10

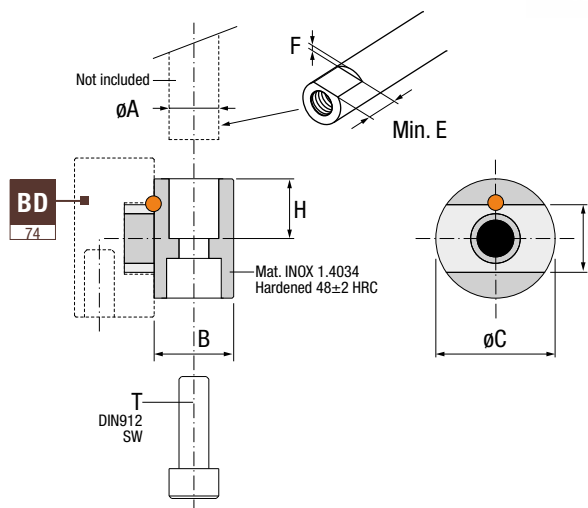

Max. 150°C

LIFTER SHAFT

ES Varilla Figura DE Stange für Geteilten Auswerfer
IT Asta per inserto figura PT Haste Balancé FR Queue d'Aronde

● Cad Insertion Point

Ref.	A	E	L	M	U	V	X
VI.064200	6	10	15	214	0.5	12	5
VI.085200	8	12	15	217	0.5	12	10
VI.106200	10	14	20	219	0.5	14	15
VI.127200	12	16	20	222	1	14	20

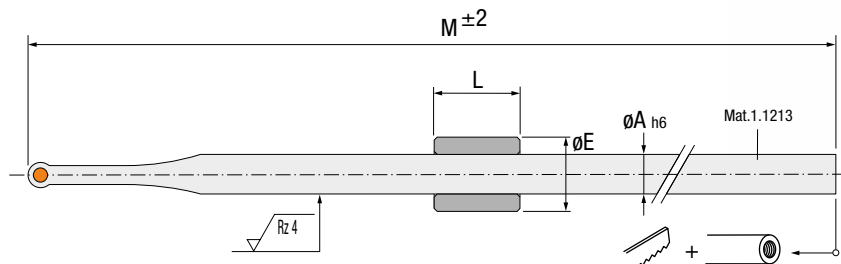

VI

Installation Guidelines

Consejos de Instalación · Richtlinien zur Installation · Consigli di Installazione · Instruções de Instalação · Mode d'Installation

Patented

Max. 150°C

IMPORTANT!
Machine
Mecanizar
Bearbeiten
Da aggiustare
Maquinar
Usiner

