

DOUBLE RACK SYSTEM by CUMSA

COMPARE

Comparativa · Vergleich · Confronto · Comparativo · Comparison

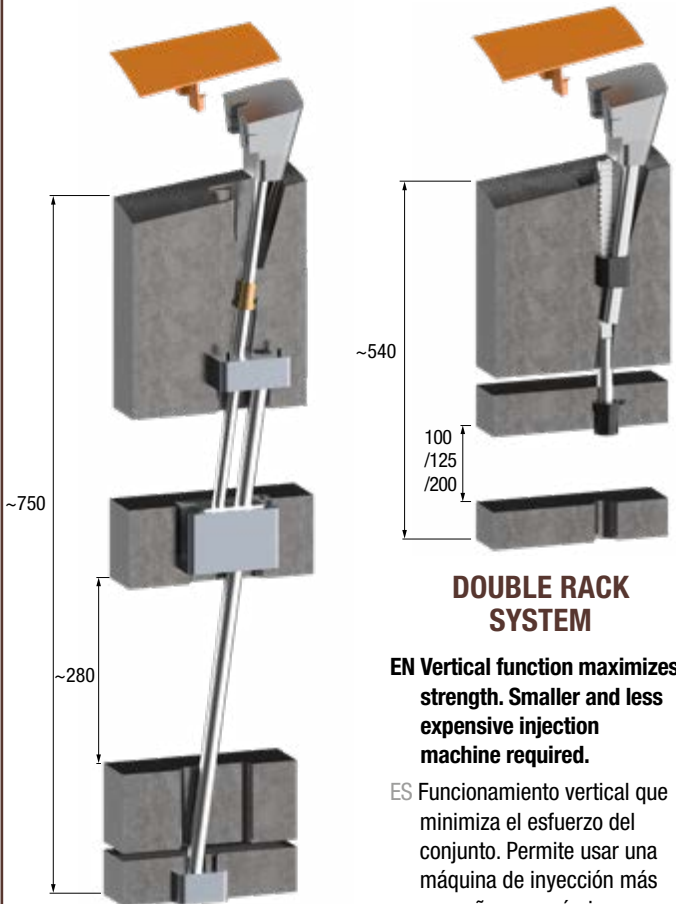

CONVENTIONAL SYSTEM

EN Eliminates the need for high-precision angled housings in the core plates.

ES Elimina los complicados taladros inclinados de alta precisión.

DE Es wird keine hochpräzise Schrägbohrung in der Formplatte benötigt.

IT Elimina le complicate lavorazioni inclinate ad alta precisione.

PT Elimina a necessidade de furos inclinados com precisão.

FR Terminé les logements inclinés d'haute précision.

DOUBLE RACK SYSTEM

EN Vertical function maximizes strength. Smaller and less expensive injection machine required.

ES Funcionamiento vertical que minimiza el esfuerzo del conjunto. Permite usar una máquina de inyección más pequeña y económica.

DE Vertikale Funktion mit maximaler Kraft. Ein kleineres Werkzeug kann eventuell eine kleinere und günstigere Spritzgießmaschine benötigen.

IT Funzionamento verticale che minimizza lo sforzo. Permette di usare una macchina d'iniezione più piccola ed economica.

PT Funcionamento na vertical minimizando o esforço. Permite o uso de máquinas de injeção de menores dimensões e mais económicas.

FR Fonctionnement vertical réduisant les efforts. Permet de réduire la dimension de la presse d'injection et ainsi de réaliser des économies.

Neutral angles ($\beta^\circ=0^\circ$)

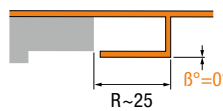

$S \geq R$

DR.xx100L-16
KR.xx200L-16
DR.xx125L-12
KR.xx125L-12
XR.xx100L-24

Positive Angles ($\beta^\circ>0^\circ$)

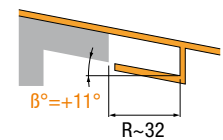

$S \geq R$

DR.xx100L-20
DR.xx125L-16
KR.xx125L-16
XR.xx100L-24

Negative Angles ($\beta^\circ<0^\circ$)

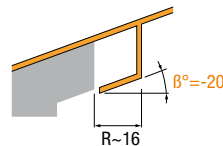

$S \geq R$

DR.xx100L-12
KR.xx200 L-12
DR.xx125L-8
KR.xx125L-8
XR.xx100L-24

IMPORTANT !

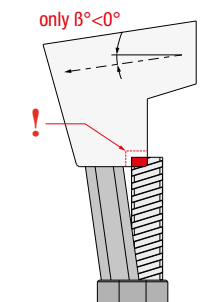

Stroke 100 (DR) Stroke 200 (KR) (Multiply S value x2)

β°	DR.xx100L-8		DR.xx100L-12	
	S (- β°)	S (+ β°)	S (- β°)	S (+ β°)
0	14.0	14.0	21.2	21.2
1	14.0	14.0	21.1	21.3
2	13.9	14.1	21.1	21.4
3	13.9	14.1	21.0	21.5
4	13.9	14.1	20.9	21.5
5	13.8	14.2	20.8	21.6
6	13.8	14.2	20.7	21.7
7	13.8	14.3	20.7	21.8
8	13.7	14.3	20.6	21.9
9	13.7	14.3	20.5	22.0
10	13.7	14.4	20.4	22.0
11	13.6	14.4	20.4	22.1
12	13.6	14.4	20.3	22.2
13	13.6	14.5	20.2	22.3
14	13.5	14.5	20.1	22.4
15	13.5	14.6	20.1	22.5
16	13.5	14.6	20.0	22.6
17	13.4	14.6	19.9	22.7
18	13.4	14.7	19.8	22.8
19	13.4	14.7	19.8	22.9
20	13.3	14.8	19.7	23.0
21	13.3	14.8	19.6	23.1
22	13.2	14.9	19.5	23.2
23	13.2	14.9	19.4	23.3
24	13.2	14.9	19.4	23.4
25	13.1	15.0	19.3	23.5
26	13.1	15.0	19.2	23.7
27	13.1	15.1	19.1	23.8
28	13.0	15.1	19.0	23.9
29	13.0	15.2	19.0	24.0
30	12.9	15.2	18.9	24.2
31	12.9	15.3	18.8	
32	12.9	15.4	18.7	
33	12.8	15.4	18.6	
34	12.8	15.5	18.5	
35	12.7	15.5	18.5	
36	12.7		18.4	
37	12.7		18.3	
38	12.6		18.2	
39	12.6		18.1	
40	12.5		18.0	
45	12.3		17.5	
50	12.0		16.9	
55	11.7		16.3	
60	11.3		15.5	

SELECTION TABLE: WHICH DR / KR DO I NEED?

ES TABLA DE SELECCIÓN: Qué DR / KR / XR necesito?

DE AUSWAHLTABELLE: Welcher DR / KR / XR ist am besten geeignet?

IT TABELLA PER SCELTA: Di quale DR / KR / XR ho bisogno?

PT TABELA DE SELEÇÃO: Qual é o DR / KR / XR que preciso?

FR TABLEAU DE CORRESPONDANCE: Quel est le DR / KR que j'ai besoin?



Stroke 100 (DR) Stroke 200 (KR) (Multiply S value x2)

	DR.xx100L-16		DR.xx100L-20	
	S (-β°)	S (+β°)	S (-β°)	S (+β°)
	28.6		36.4	
28.5	28.8	36.1	36.6	
28.3	28.9	35.9	36.8	
28.2	29.1	35.7	37.1	
28.1	29.2	35.4	37.3	
27.9	29.4	35.2	37.5	
27.8	29.5	35.0	37.8	
27.7	29.7	34.8	38.1	
27.5	29.8	34.6	38.3	
27.4	30.0	34.4	38.6	
27.2	30.2	34.2	38.8	
27.1	30.3	33.9	39.1	
27.0	30.5	33.7	39.4	
26.8	30.7	33.5	39.7	
26.7	30.8	33.3	40.0	
26.6	31.0	33.1	40.3	
26.5	31.2	32.9	40.6	
26.3	31.4	32.7	40.9	
26.2	31.6	32.5	41.2	
26.1	31.8	32.3	41.6	
25.9	32.0	32.1	41.9	
25.8	32.2	31.9		
25.6	32.4	31.7		
25.5	32.6	31.5		
25.4	32.8	31.3		
25.2	33.1	31.1		
25.1		30.9		
25.0		30.7		
24.8		30.4		
24.7		30.2		
24.6		30.0		
24.4		29.8		
24.3		29.6		
24.1		29.4		
24.0		29.2		
23.8		29.0		
23.7		28.7		
23.5		28.5		
23.4		28.3		
23.2		28.1		
23.1		27.8		
22.2		26.6		
21.3		25.1		
20.3		23.9		
19.1		22.3		

Stroke 125 (DR / KR)

β°	DR.xx125L-8		DR.xx125L-12		DR.xx125L-16		DR.xx125L-20	
	KR.xx125L-8		KR.xx125L-12		KR.xx125L-16		KR.xx125L-20	
	S (-β°)	S (+β°)	S (-β°)	S (+β°)	S (-β°)	S (+β°)	S (-β°)	S (+β°)
0	17.5		26.5		35.8		45.4	
1	17.5	17.6	26.4	26.6	35.6	36.0	45.2	45.7
2	17.4	17.6	26.3	26.7	35.4	36.2	44.9	46.0
3	17.4	17.6	26.2	26.8	35.3	36.3	44.6	46.3
4	17.3	17.7	26.1	26.9	35.1	36.5	44.3	46.6
5	17.3	17.7	26.0	27.0	34.9	36.7	44.0	46.9
6	17.3	17.8	25.9	27.1	34.7	36.9	43.8	47.3
7	17.2	17.8	25.8	27.2	34.6	37.1	43.5	47.6
8	17.2	17.9	25.7	27.3	34.4	37.3	43.2	47.9
9	17.1	17.9	25.7	27.4	34.2	37.5	43.0	48.2
10	17.1	18.0	25.6	27.6	34.1	37.7	42.7	48.6
11	17.1	18.0	25.5	27.7	33.9	37.9	42.4	48.9
12	17.0	18.1	25.4	27.8	33.7	38.1	42.2	49.3
13	17.0	18.1	25.3	27.9	33.6	38.3	41.9	49.6
14	16.9	18.2	25.2	28.0	33.4	38.6	41.7	50.0
15	16.9	18.2	25.1	28.1	33.2	38.8	41.4	50.4
16	16.8	18.3	25.0	28.2	33.1	39.0	41.1	50.7
17	16.8	18.3	24.9	28.4	32.9	39.2	40.9	51.1
18	16.8	18.4	24.8	28.5	32.7	39.5	40.6	51.5
19	16.7	18.4	24.7	28.6	32.6	39.7	40.4	52.0
20	16.7	18.5	24.6	28.7	32.4	40.0	40.1	52.4
21	16.6	18.5	24.5	28.9	32.2	40.2	39.9	
22	16.6	18.6	24.4	29.0	32.1	40.5	39.6	
23	16.5	18.6	24.3	29.2	31.9	40.8	39.4	
24	16.5	18.7	24.2	29.3	31.7	41.0	39.1	
25	16.4	18.7	24.1	29.4	31.6	41.3	38.8	
26	16.4	18.8	24.0	29.6	31.4		38.6	
27	16.3	18.9	23.9	29.7	31.2		38.3	
28	16.3	18.9	23.8	29.9	31.1		38.1	
29	16.2	19.0	23.7	30.1	30.9		37.8	
30	16.2	19.1	23.6	30.2	30.7		37.5	
31	16.1	19.1	23.5		30.5		37.3	
32	16.1	19.2	23.4		30.3		37.0	
33	16.0	19.3	23.3		30.2		36.7	
34	16.0	19.4	23.2		30.0		36.5	
35	15.9	19.4	23.1		29.8		36.2	
36	15.9		23.0		29.6		35.9	
37	15.8		22.9		29.4		35.7	
38	15.8		22.7		29.2		35.4	
39	15.7		22.6		29.0		35.1	
40	15.7		22.5		28.8		34.8	
45	15.4		21.9		27.8		33.3	
50	15.0		21.1		26.7		31.7	
55	14.6		20.3		25.4		29.9	
60	14.1		19.4		23.9		27.9	

Stroke 100 (XR)

β°	XRxx100L-24		XRxx100L-28		XRxx100L-32		XRxx100L-36	
	S (-β°)	S (+β°)	S (-β°)	S (+β°)	S (-β°)	S (+β°)	S (-β°)	S (+β°)
0	44.5		53.2		62.5		72.7	
1	44.2	44.9	52.7	53.7	61.8	63.2	71.7	73.6
2	43.8	45.2	52.2	54.2	61.2	63.9	70.9	74.5
3	43.5	45.6	51.7	54.7	60.5	64.6	70.0	75.5
4	43.2	46.0	51.3	55.2	59.9	65.3	69.1	76.5
5	42.9	46.3	50.8	55.8	59.2	66.1	68.3	77.6
6	42.5	46.7	50.4	56.3	58.6	66.9	67.5	78.7
7	42.2	47.1	49.9	56.9	58.0	67.7	66.7	79.8
8	41.9	47.5	49.5	57.5	57.4	68.5	65.9	
9	41.6	47.9	49.0	58.1	56.9	69.4	65.2	
10	41.3	48.3	48.6	58.7	56.3	70.2	64.4	
11	41.0	48.7	48.2	59.3	55.7	71.1	63.7	
12	40.7	49.2	47.8	59.9	55.2		62.9	
13	40.4	49.6	47.4	60.6	54.6		62.2	
14	40.1	50.1	46.9	61.3	54.1		61.5	
15	39.8	50.6	46.5	62.0	53.5		60.8	
16	39.5	51.0	46.1		53.0		60.1	
17	39.2	51.5	45.7		52.5		59.4	
18	38.9	52.1	45.3		51.9		58.8	
19	38.6	52.6	44.9		51.4		58.1	
20	38.3		44.5		50.9		57.5	
21	38.0		44.2		50.4		56.8	
22	37.7		43.8		49.9		56.2	
23	37.4		43.4		49.4		55.5	
24	37.2		43.0		48.9		54.9	
25	36.9		42.6		48.4		54.3	
26	36.6		42.2		47.9		53.6	
27	36.3		41.8		47.4		53.0	
28	36.0		41.5		46.9		52.4	
29	35.7		41.1		46.4		51.8	
30	35.4		40.7		45.9		51.2	
31	35.1		40.3		45.4		50.6	
32	34.8		39.9		44.9		50.0	
33	34.5		39.5		44.4		49.4	
34	34.2		39.1		44.0		48.8	
35	33.9		38.7		43.5		48.2	
36	33.6		38.4		43.0		47.6	
37	33.3		38.0		42.5		46.9	
38	33.0		37.6		42.0		46.3	
39	32.7		37.2		41.5		45.7	
40	32.4		36.8		41.0		45.1	
45	30.8		34.7		38.4		42.0	
50								
55								
60								

Special β° angles possible under request
ES Posibilidad de ángulos β° especiales DE Sonderwinkel auf Anfrage möglich (β°) IT E' possibile avere angolazioni β° speciali su richiesta PT Possibilidade de ângulos β° especiais FR Possibilité de réaliser des angles β° spéciaux.

DOUBLE RACK LIFTER

ES Doble Cremallera DE Zweifach Zahnstangen-System
IT Doppia Cremagliera PT Duplo Rack FR Double Cremailere

● Cad Insertion Point

DR

Patented

Max. 150°C

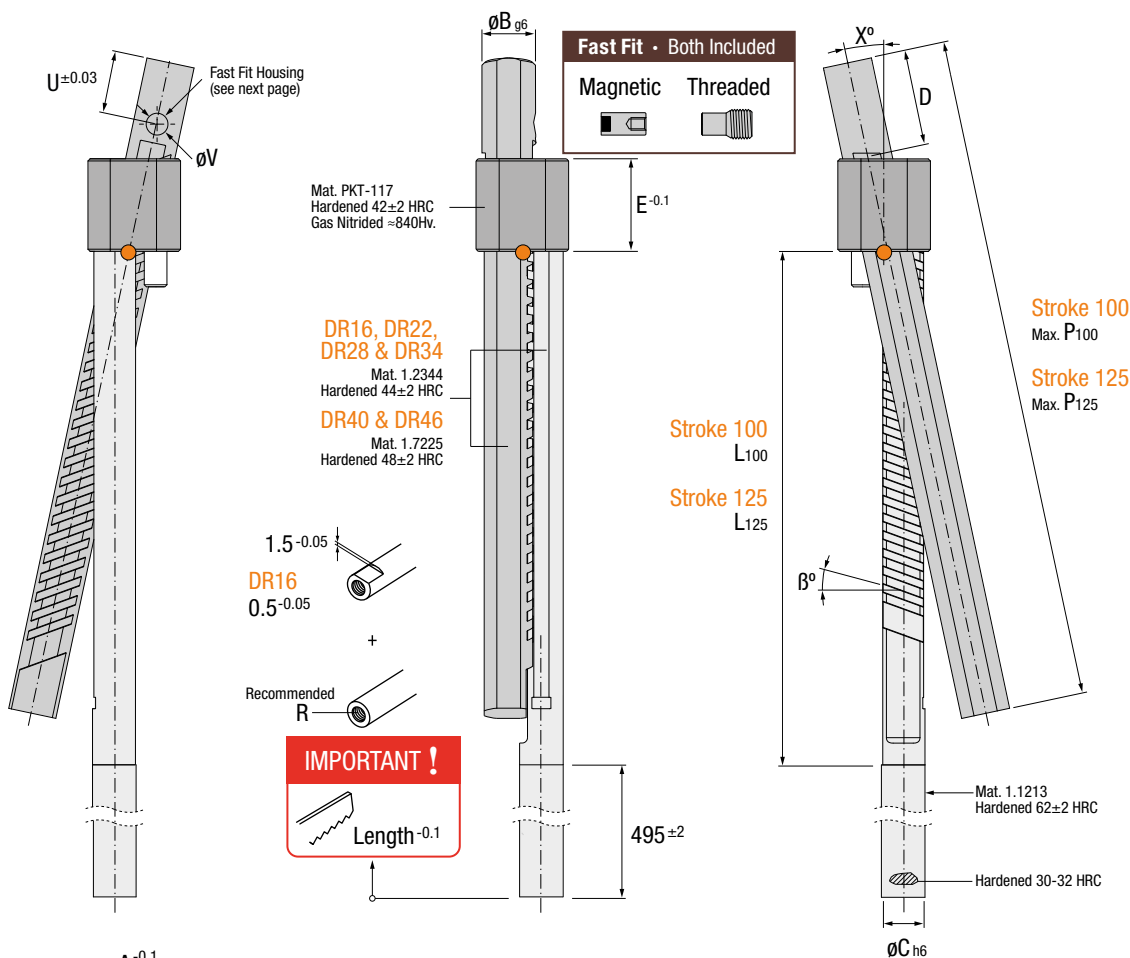

IMPORTANT !
Mirror Part.
Pieza Simétrica.
Symmetrisches Teil.
Versione a Specchio.
Peça em Espelho.
Pièce en Miroir.

Stroke 100	Stroke 125	X°	A	B	C	D	E	L100	P100	L125	P125	Q	R	T	U	V	Stroke 100-S	Stroke 125-S	SWa	
DR.16100L-x	-	8 12 16	16	9	8	20	20	142	178	-	-	4	M5	M5	10	6	DR.16100L-x-S	-	3	
DR.22100L-x	DR.22125L-x	8 12 16	22	12	12	30	22	148	202	202	261	6.5	M6	M6	17	8	DR.22100L-x-S	DR.22125L-x-S	4	
DR.28100L-x	DR.28125L-x	8 12 16	20	28	16	14	36	28	152.5	214	194.5	266	8.5	M8	M8	23	8	DR.28100L-x-S	DR.28125L-x-S	5
DR.34100L-x	DR.34125L-x	8 12 16	20	34	20	16	36	34	160.5	227	188.5	264	10.5	M8	M8	23	8	DR.34100L-x-S	DR.34125L-x-S	5
DR.40100L-x	DR.40125L-x	8 12 16	20	40	22	20	36	40	170	244	204	284	10.5	M10	M10	20	10	DR.40100L-x-S	DR.40125L-x-S	6
DR.46100L-x	DR.46125L-x	8 12 16	20	46	24	24	42	46	175	258	201	289	10.5	M10	M12	26	10	DR.46100L-x-S	DR.46125L-x-S	8

HOW TO ORDER !

Check page 50-51 for Min / Max β values

β° < 0 & β° = 0 β° > 0

A Stroke X° β A Stroke X° β

DR 28 100L - 12 -10 Standard DR 28 100L - 12 +10

DR 28 100L - 12 -S -10 Symmetrical DR 28 100L - 12 -S +10

A Stroke X° β A Stroke X° β

INSTALLATION GUIDELINES

ES Consejos de Instalación DE Richtlinien zur Installation
 IT Consigli di Installazione PT Instruções de Instalação FR Mode d'Installation

DR

Core Housing
 Alojamiento Placa Punzón
 Kerngehäuse
 Sede nel Punzone
 Alojamento Bucha
 Logement dans l'empreinte

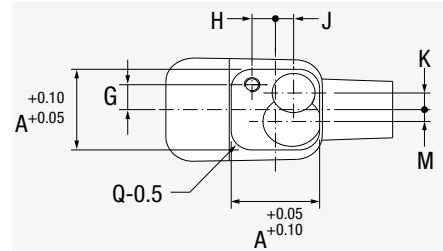
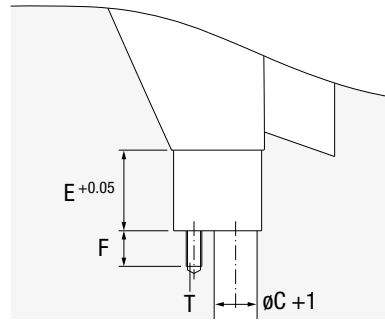
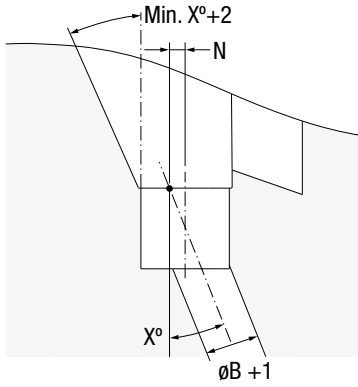

Patented

Max. 150°C

Stroke 100	Stroke 125	Stroke 200	F	FR1	FR2	G	H	J	K	M	N	S	T	W	Y	Z	SWb
DR.16100L-..	-	-	10	4.9	M8x1	4.6	4.6	3	2.35	3	2.8	2.5	M5	6	9	M4	4
DR.22100L-..	DR.22125L-.. / KR.22125L-..	-	13	5.3	M10x1	5.6	5.6	4.2	3.7	4.2	3.5	2.5	M6	8	12	M4	5
DR.28100L-..	DR.28125L-.. / KR.28125L-..	-	16	5.3	M10x1	7.5	7.5	5	5.4	4.8	4.8	2.5	M8	8	13.5	M4	5
DR.34100L-..	DR.34125L-.. / KR.34125L-..	-	16	5.3	M10x1	10.5	8	7	7	5	6	4	M8	8	16	M4	5
DR.40100L-..	DR.40125L-.. / KR.40125L-..	-	20	8.5	M12x1	11	11	7	8	7	7	4	M10	10	20	M6	6
DR.46100L-..	DR.46125L-.. / KR.46125L-..	-	25	8.5	M12x1	13	13	8	8	9	9	5	M12	10	24	M6	6
-	-	KR.58200L-..	28	8.5	M16x1.5	15.5	15.5	10	12.2	11.2	10	5	M14	12	30	M6	8
-	-	KR.76200L-..	36	14	M16x1.5	21	21	13	15.2	15.2	12	6	M18	12	36	M6	8

Installation

Instalación · Montage · Montaggio · Instalação · Montage

