

VACUUMJET SYSTEM

by CUMSA

WHAT DOES VACUUM STAND FOR?

To vacuum is to remove the air out of a space, therefore, leaving this space completely empty, creating negative pressure.

WHY IS IT INTERESTING TO CREATE A VACUUM INSIDE MOLDS?

During the injection process there is an invisible pressure within the cavity, making it difficult to fill, making the pressure in the air difficult to fill! The air is cornered, compressed and heated by plastic, and is pushed outside the mold through its clearances, complicating therefore the cavity filling, and creating problems in the process, in the plastic part and slowing down the cycle time.

¡We need to extract the air from the cavity or at least minimize its influence in the process!

HOW CAN WE EXTRACT THE AIR?

CUMSA has developed a series of products to enable the vacuuming of mold cavities. Discover these products in this catalogue!

From just a 20-30% of vacuum created, improvements in the process can be observed; therefore, it is important to balance the level of vacuum with the time needed, to find the best option to suit your particular needs.

WHAT BENEFITS COULD MY MOLD ACHIEVE WITH THE VACUUM?

In the injected plastic part:

- Superior visual appearance (less sink marks).
- Dimensional stability (less weld lines).
- Uniform color.
- High mechanical resistance due to perfect plastic distribution.

In the process:

- Reduced cycle time.
- Lower injection temperature & pressure.
- Increase in production.

WHAT IS NEEDED TO CREATE THE VACUUM?

- Complete sealing of the mold to achieve optimal vacuum results.
- 1 or 2 electrovalves, depending on the model selected model.
- No need of any additional vacuum pump/mechanism.

VACUUMJET OPERATIONAL PROCEDURE

MOLD CLOSED

With the mold closed, air is trapped inside the cavity. If injection starts, the air will be cornered, heated and compressed by the plastic, producing poor quality plastic parts.

We have to create vacuum!

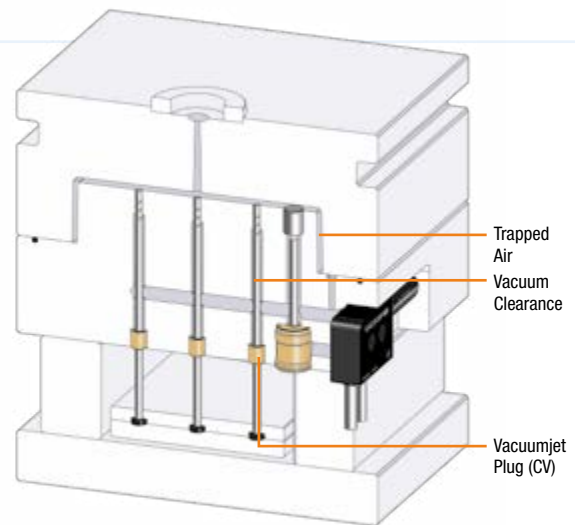

CREATING THE VACUUM IN THE CAVITY

To optimize the injection process we have to remove the air from the cavity.

There are several methods to accomplish this, but in all of them it is the injected plastic that pushes out the air. With VACUUMJET, when it is activated prior to the injection, a valve is opened and the air is vacuumed, therefore, leaving the cavity in optimal conditions for injection.

→ Air Flow

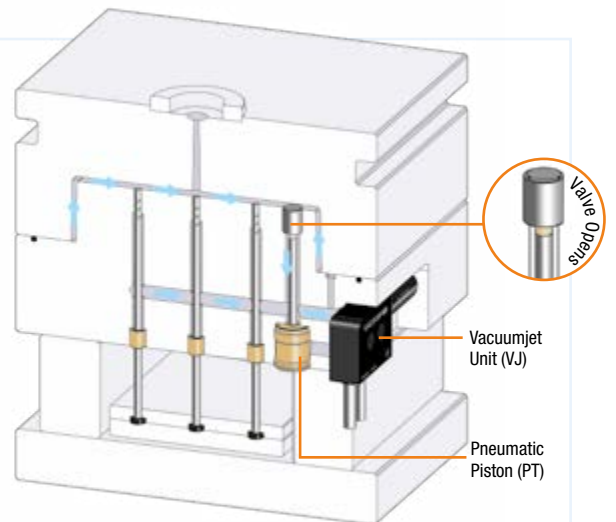

INJECTION STARTS

The VACUUMJET continues sucking the air during all the injection process, to guarantee the maximum ease of the plastics fluidity, therefore reducing the pressure needed.

EJECTION PROCESS

When the injection is finished, the VACUUMJET stops, and as with all molds, the plastic is cooled and the part is ejected...but with the VACUUMJET system, we obtain a greater quality plastic part with at least the same injection time, if not faster, and without altering the optimal injection parameters.

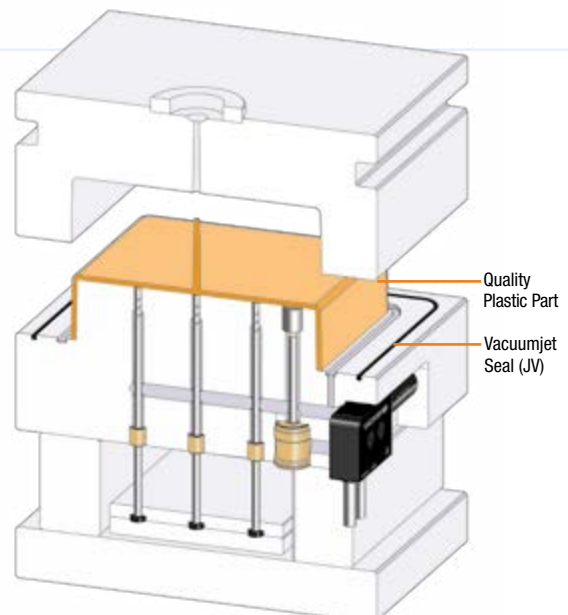

VG

Patented

Max. 80°C

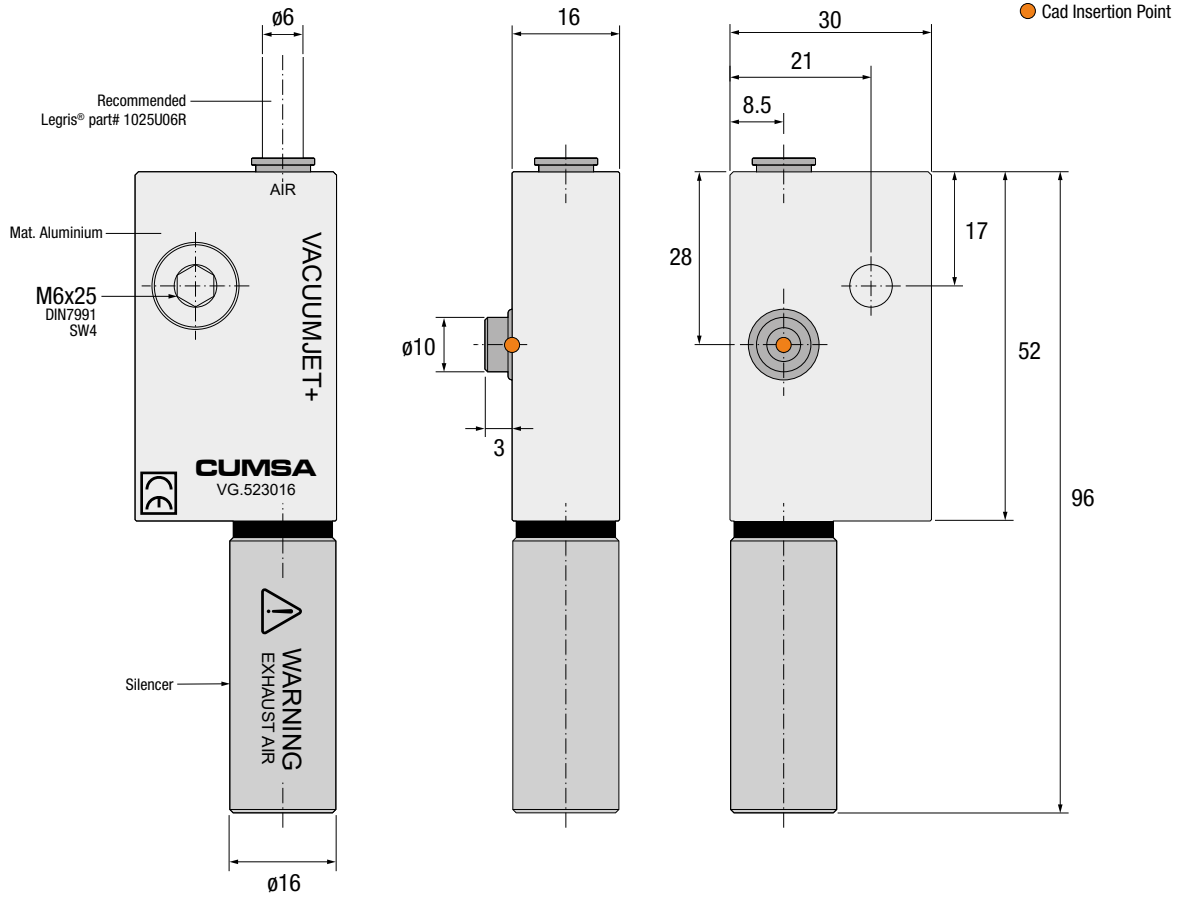

Ref.	Supply Pressure	Max. Vacuum	Max. Flow	Consumption
VG.523016	5-6 BAR	-900 mbar	75 L./ Min.	60 L./ Min.

IMPORTANT ! Several units can be connected together in the same Vacuum circuit.
 En un solo circuito de vacío se pueden conectar varias unidades.
 Mehrere Einheiten können zusammen im gleichen Vakuumkreislauf angeschlossen werden.
 In un solo circuito si possono collegare diverse unità.
 Em apenas um circuito de ar podemos ligar varias unidades.
 Avec un seul circuit d'air nous pouvons relier plusieurs unités.

Installation Guidelines

Consejos de Instalación · Richtlinien zur Installation · Consigli di Installazione · Instruções de Instalação · Mode d'Installation

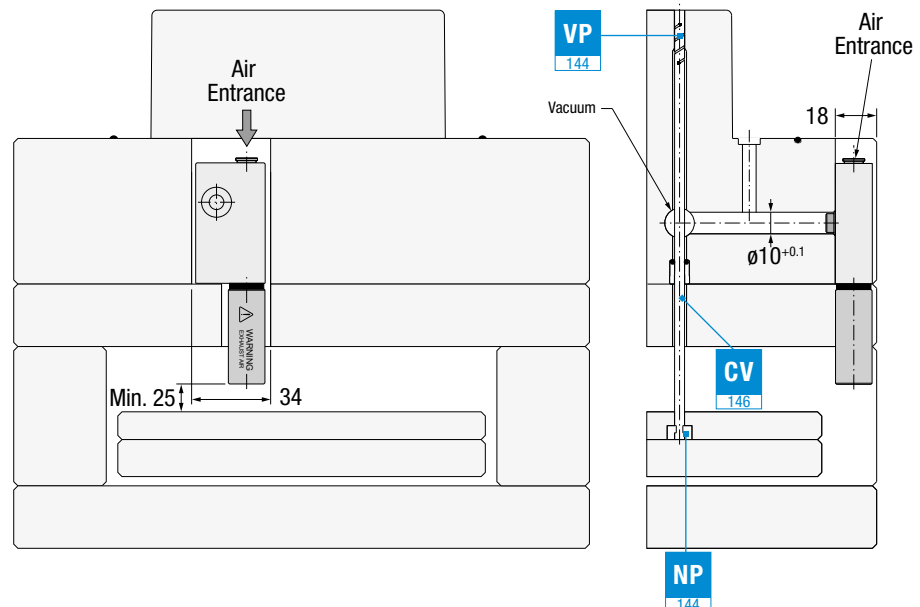

INSTALLATION GUIDELINES

ES Consejos de Instalación DE Richtlinien zur Installation
IT Consigli di Installazione PT Instruções de Instalação FR Mode d'Installation



VG

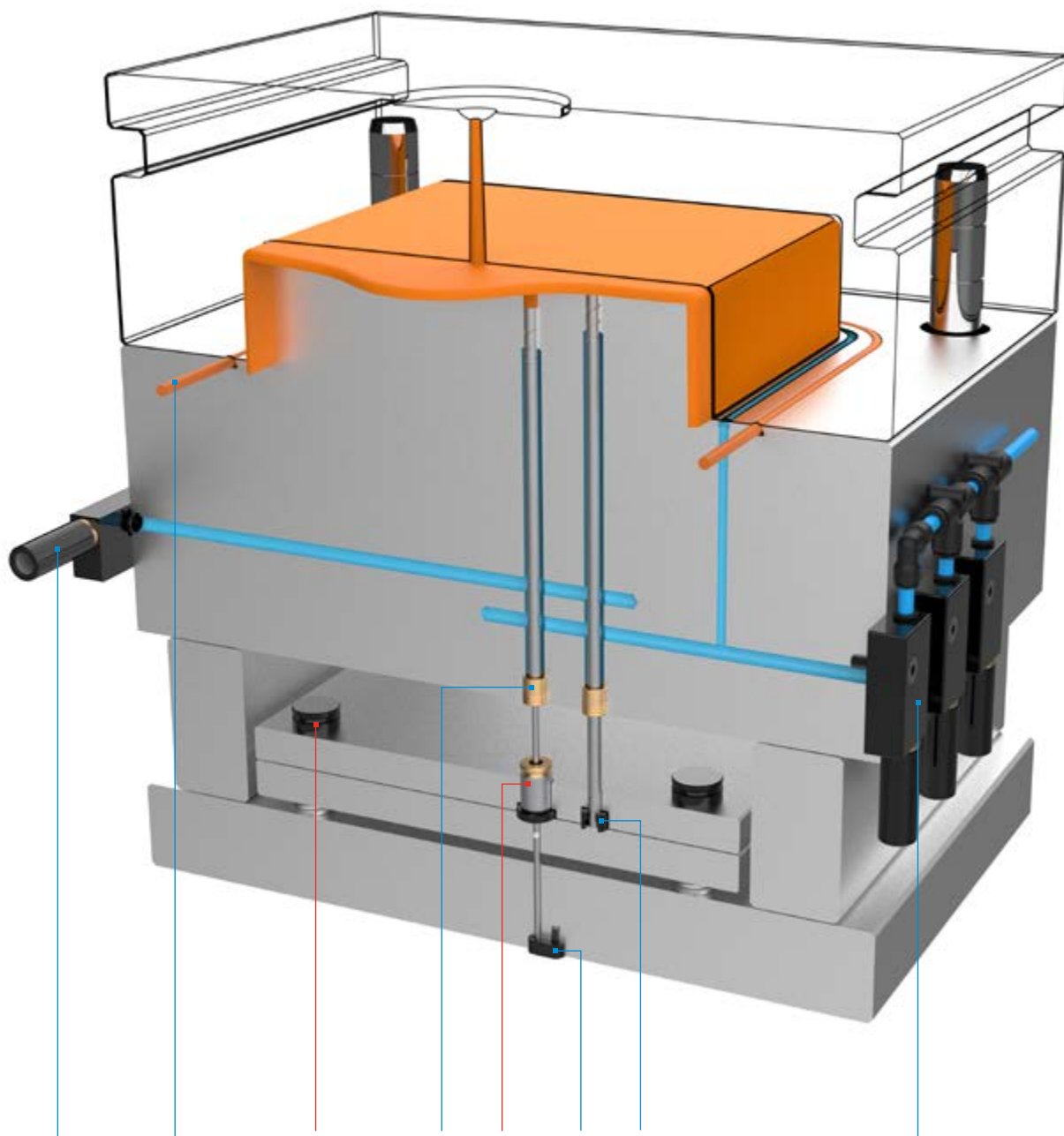

Patented

Max.
80°C

Vacuum