

CUMSA

INNOVATIVE SOLUTIONS
FOR YOUR MOLDS

SPRUE BUSHING

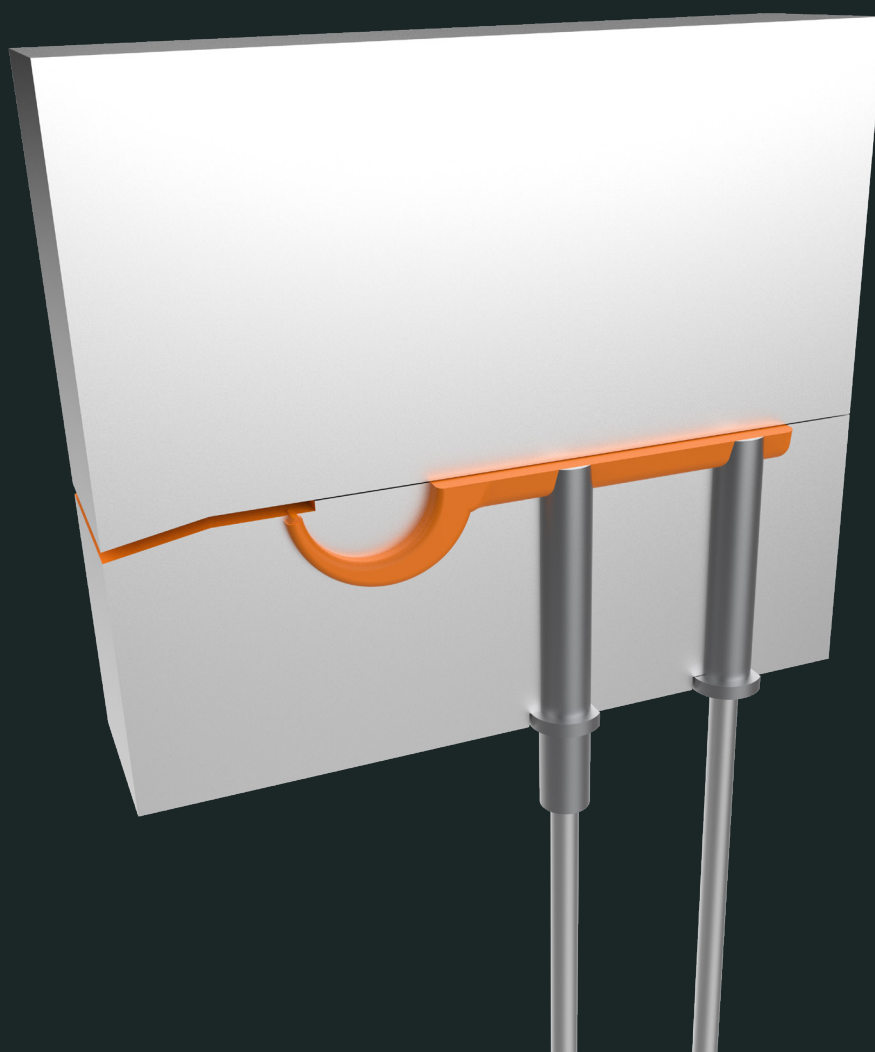

AVOID THE BIG PROBLEMS

ACCESSORIES

EN

SPRUE BUSHING HARDENED

ES Casquillo de expulsión de colada templado DE Gehärtete Angussbuchse

PT Casquilho canal temperado IT Boccola di espulsione temprata per canale di colata FR Douille canal trempé

SERIE 51110

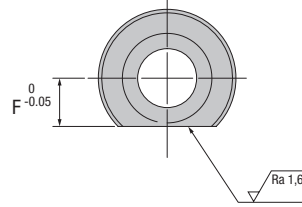
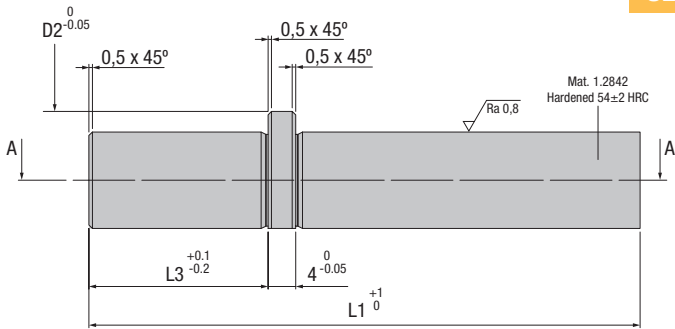

STANDARD

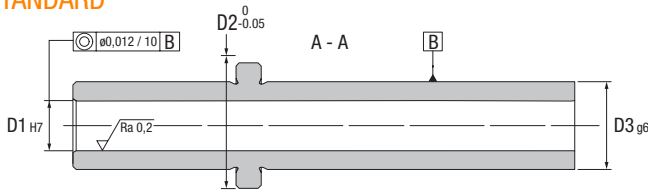

STANDARD	CONICAL	D2	F	L3	D3	L1	D1
S51110/20-12-60-6	CS51110/20-12-60-6	16	6	20	12	60	6
S51110/26-14-xxx-8	CS51110/26-14-xxx-8	20	7	26	14	80	100
S51110/26-16-xxx-10	CS51110/26-16-xxx-10	22	8	26	16	80	100
S51110/50-14-120-8	CS51110/50-14-120-8	20	7	50	14	120	8
S51110/50-16-120-10	CS51110/50-16-120-10	22	8	50	16	120	10

CONICAL

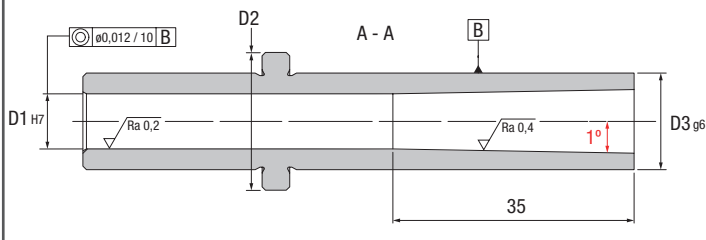

IMPORTANT !

Replace the **xxx** in the reference with the required L1 dimension.
 Sustituir la **xxx** de la referencia por la cota L1 deseada.
 Ersetzen Sie bei der Referenz das **xxx** durch die gewünschte L1 Dimension.
 Sostituite la **xxx** del codice con la dimensione L1 desiderata.
 Substituir o **xxx** da referencia pela cota L1 desejada.
 Remplacez la valeur **xxx** par la valeur L1 désirée.

SERIE 51011

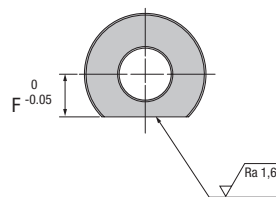
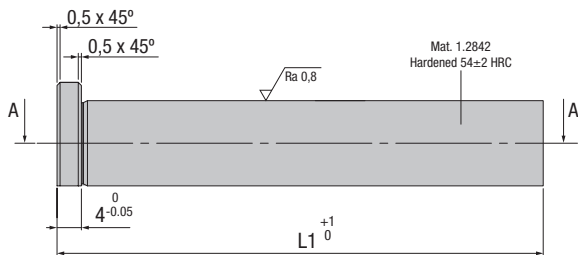

STANDARD

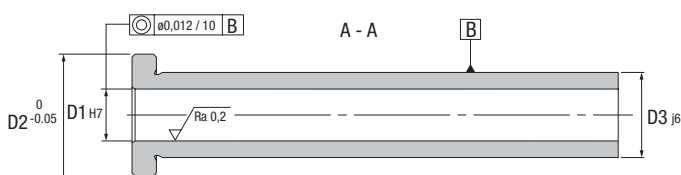

STANDARD	CONICAL	D2	F	D3	L1	D1
S51011/10-80-6	CS51011/10-80-6	16	5	10	80	6
S51011/12-80-8	CS51011/12-80-8	18	6	12	80	8
S51011/14-xxx-8	CS51011/26-14-xxx-8	20	7	14	80	100
S51011/16-xxx-10	CS51011/50-16-xxx-10	22	8	16	80	100

CONICAL

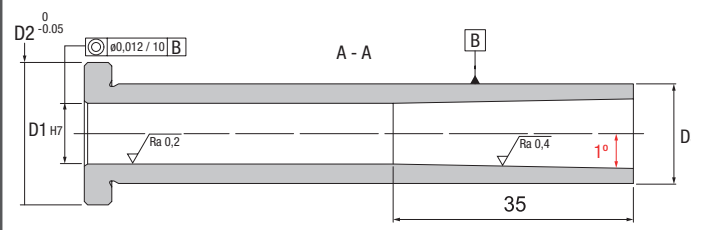

IMPORTANT !

Replace the **xxx** in the reference with the required L1 dimension.
 Sustituir la **xxx** de la referencia por la cota L1 deseada.
 Ersetzen Sie bei der Referenz das **xxx** durch die gewünschte L1 Dimension.
 Sostituite la **xxx** del codice con la dimensione L1 desiderata.
 Substituir o **xxx** da referencia pela cota L1 desejada.
 Remplacez la valeur **xxx** par la valeur L1 désirée.

COMMON PROBLEMS TO SOLVE:

“Bayer” injection: Mostly used in the Automotive industry, needs a big plastic pillar to guide its demolding.

Big force needed to extract plastic waste, causing:

- Ejector pins breakages.
- H7 ejector holes seized up.

SPRUE BUSHING ADVANTAGES

The internal low rugosity: allows an easy plastic release.

Conical sprue bushing: for difficult and tough materials.

In case of problems, JUST **replace the standard bushing**, avoiding:

- Remake all the H7 ejector area.
- Or resize the ejector diameter.

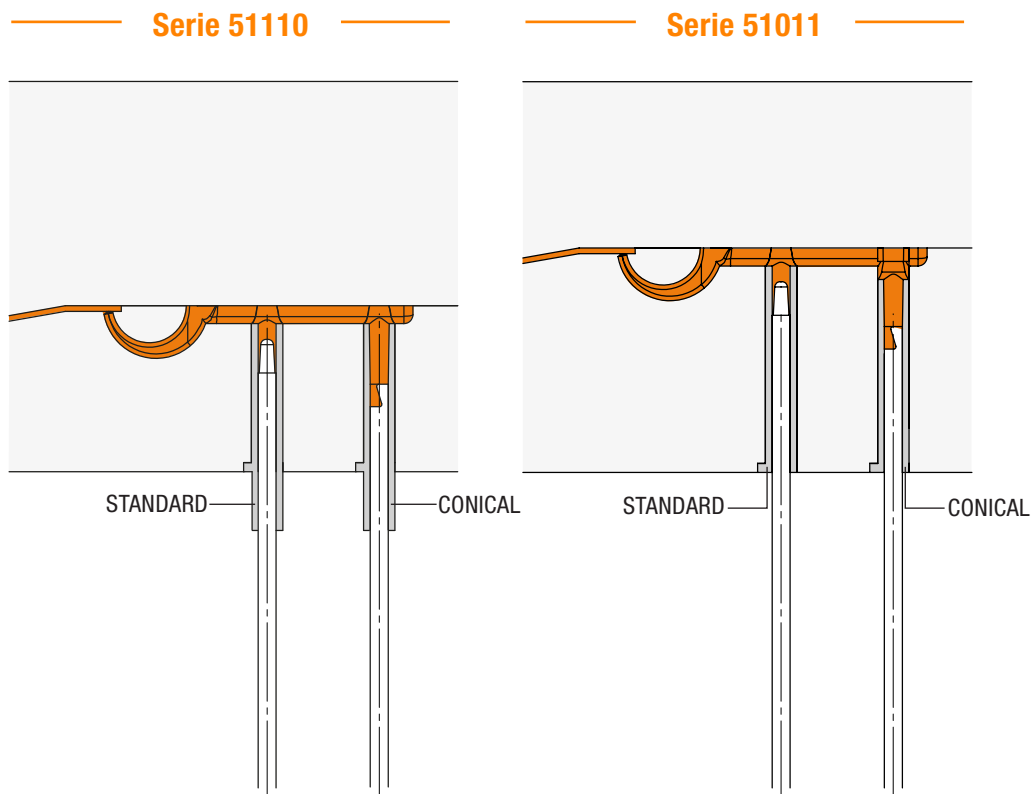

CUMSA

www.cumsa.com

Ed. 2024 - 10

Isaac Peral, 21
08960 · Sant Just Desvern
Barcelona · Spain
Tel: +34 93 473 25 52
Fax: +34 93 473 49 19
e-mail: info@cumsa.com



The future
IS HERE



CUMSA
— USA —

Tel.: +1 248 850 8385
e-mail: info@cumsausa.com

EURO
CUMSA

Tel.: +351 244 770 420
e-mail: geral@eurocumsa.pt

CUMSA
— ITALIA —

Tel.: +39 (0) 362 170 8735
e-mail: cumsaitalia@cumsa.com

CUMSA
— 坤盛 中国 —

Tel.: +86 755 2998 5783
e-mail: cumsachina@cumsa.com

CUMSA
— DEUTSCHLAND —

Tel.: +49 (0) 160 2611 003
e-mail: deutschland@cumsa.com

CUMSA ASIA PACIFIC Ltd.
Tel.: +86 755 2823 6174

NEED HELP INCORPORATING CUMSA PRODUCTS?

Contact our team at technical@cumsa.com for a free project consultation.

