

FAST & SAFE

WHAT ELSE DO YOU NEED?



WITHOUT HUMAN INVOLVEMENT

From the warehouse directly to the injection machine without the need to remove screws nor straps. With minimal human involvement required, just assemble the mold to the machine and start the production.



ENHANCED SECURITY

Mold will be perfectly closed while stored away and ready to produce plastic parts as soon as it is back in the injection machine.



ADAPTABLE TO DIFFERENT MOLD TYPES

Specially designed to be used in the most conventional mold types / configurations.



TOUGH AND COMPACT DESIGN

Perfect and simple design to fit and secure a wide range of heavy molds:

REFERENCE	MAX. MOLD SIZE
AS.462024	Up to 10 Tons
AS.582430	Up to 20 Tons
AS.764040	Up to 30 Tons

CUMSA

www.cumsa.com

Ed. 2024 - 03

Isaac Peral, 21
08960 · Sant Just Desvern
Barcelona · Spain
Tel: +34 93 473 25 52
Fax: +34 93 473 49 19
e-mail: info@cumsa.com



The future
IS HERE

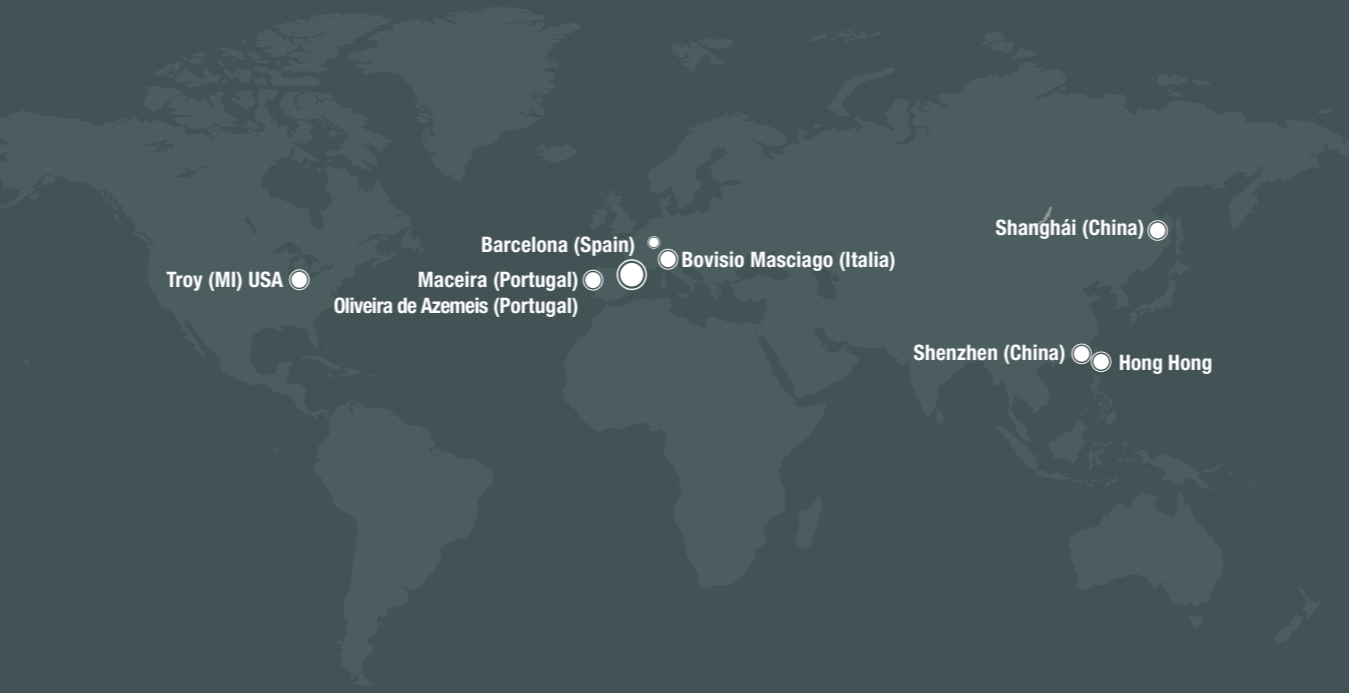

CUMSA
—USA—

Tel.: +1 248 850 8385
e-mail: info@cumsausa.com

EURO
CUMSA

Tel.: +351 244 770 420
e-mail: geral@eurocumsa.pt

CUMSA
—ITALIA—

Tel.: +39 (0) 362 170 8735
e-mail: cumsaitalia@cumsa.com

CUMSA
—坤盛 中国—

Tel.: +86 755 2998 5783
e-mail: cumsaChina@cumsa.com

CUMSA
—DEUTSCHLAND—

Tel.: +49 (0) 160 2611 003
e-mail: deutschland@cumsa.com

CUMSA ASIA PACIFIC Ltd.
Tel: +86 755 2823 6174



NEED HELP INCORPORATING CUMSA PRODUCTS?

Contact our team at technical@cumsa.com for a free project consultation.

CUMSA

INNOVATIVE SOLUTIONS
FOR YOUR MOLDS

AUTOMATIC SAFETY STRAP

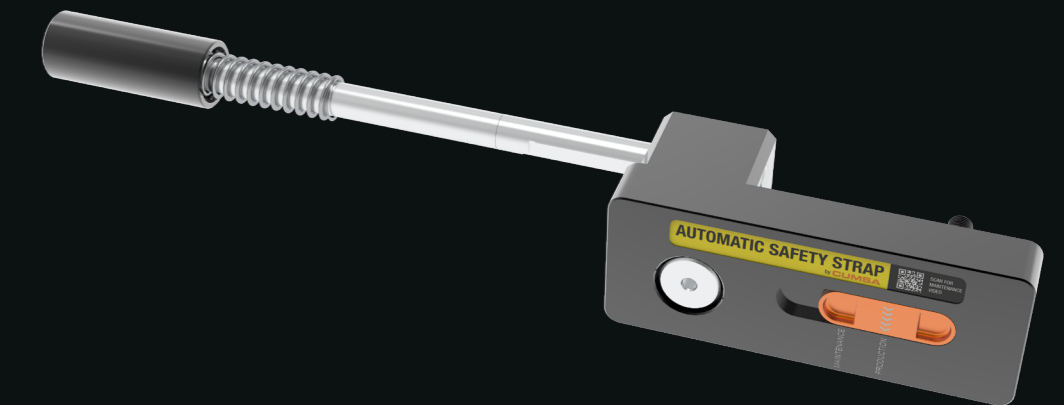

READY, SET, GO!

ACCESSORIES

AS

AUTOMATIC SAFETY STRAP

SAFETY FIRST!

Small but powerful!

Don't let its compact dimensions deceive you. A large mold, up to 30 tons, only requires one unit to securely maintain its closed position outside of the press.

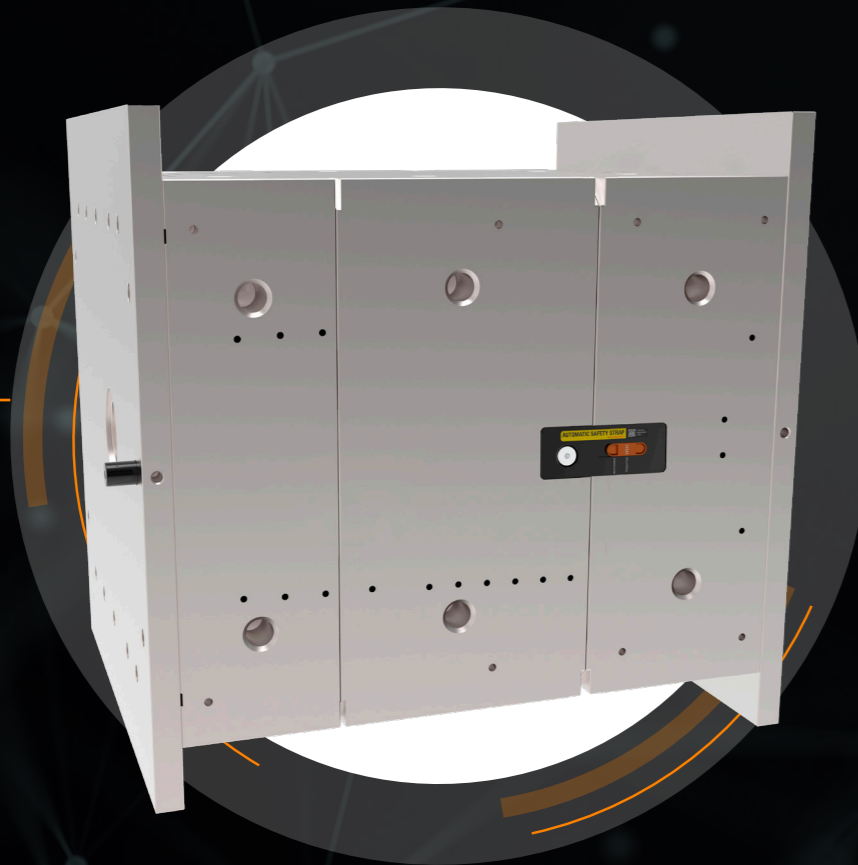

PLAY



CATALOGUE



Double Rack System

CUMSA's patented Double Rack System provides a safe, precise, and smooth movement during the injection process, making this a smart solution for our customers.

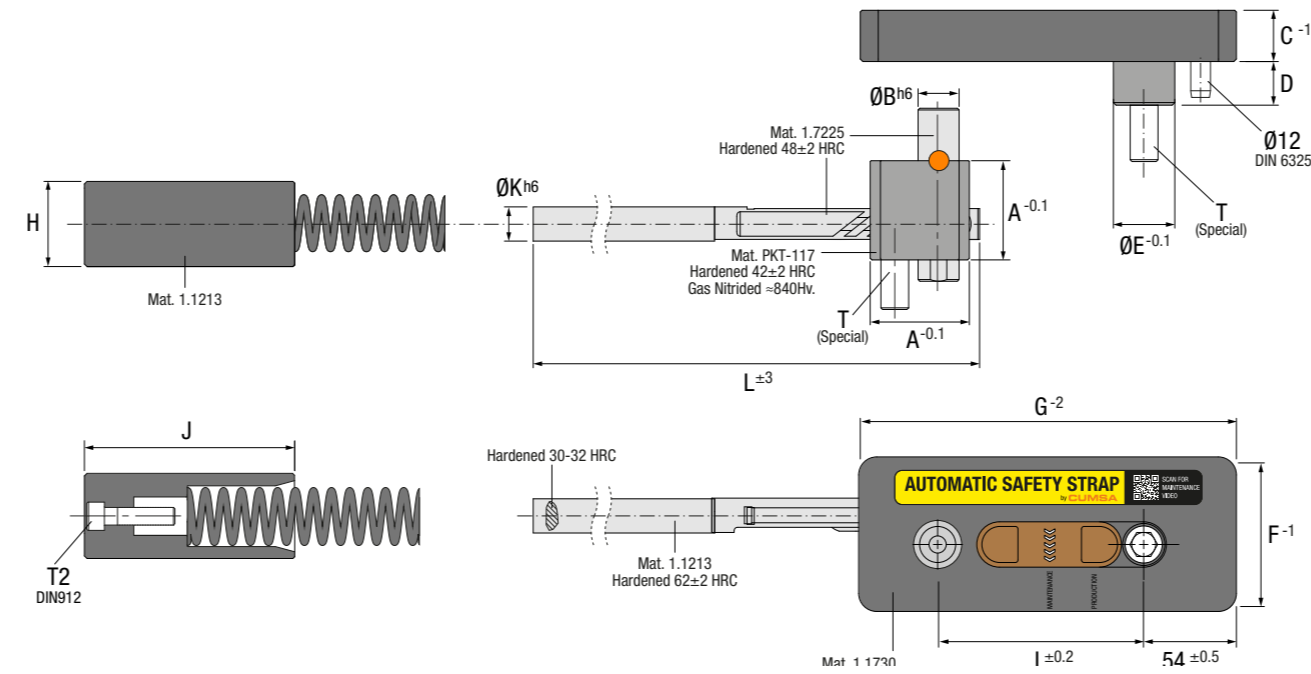

Ref.	A	B	C	D	E	F	G	H	I	J	K	L	M	N	P	Q	R	S	T	T2	U	V	W	X	Y	Z	Max. Mold Size
AS.462024	46	20	25	21	26	70	190	39	100	100	16	619	24	30	43.8	20.8	18	12.3	M12x60	M8x50	31.8	12.3	35	15	35	55	Up to 10 Tons
AS.582430	58	24	30	25	36	90	220	45	120	110	20	644	30	54	56	24	36	17	M16x70	M10x50	40	17	40	18	43.5	69	Up to 20 Tons
AS.764040	76	40	40	32	42	100	260	48	152	120	24	674	32	60	68	40	34	18	M16x90	M10x50	56	25.2	50	26	60	85	Up to 30 Tons

WAREHOUSE

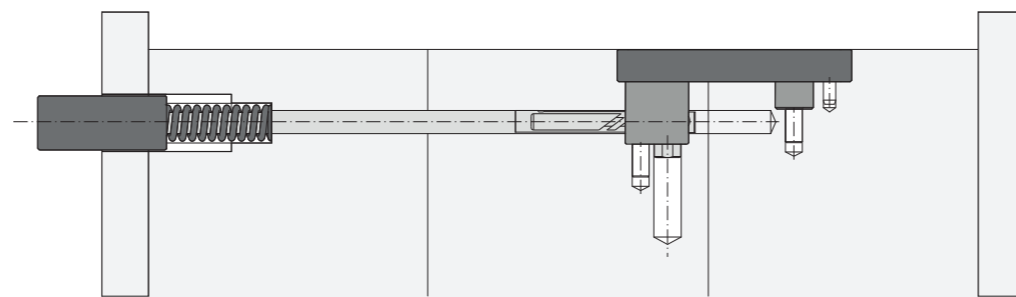

PRODUCTION

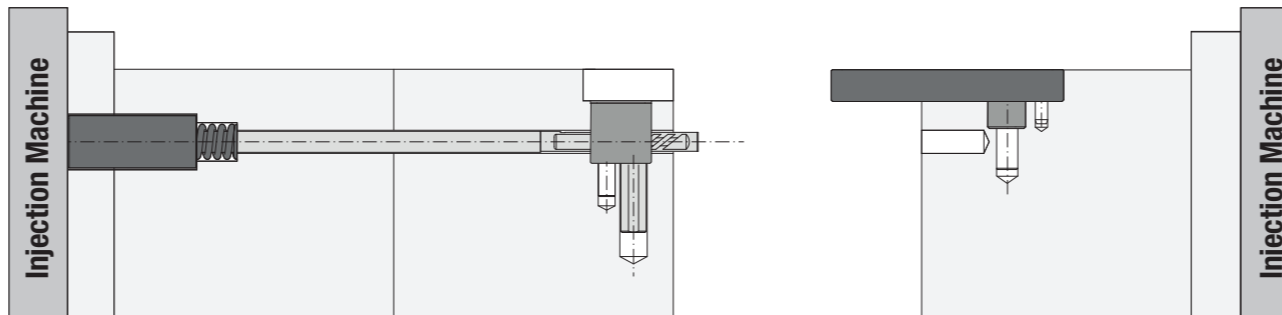

Core Housing

Alojamiento Placa Punzón · Einbaumaße PB Führung · Sede nel Punzone · Alojamento Bucha · Logement dans l'empreinte

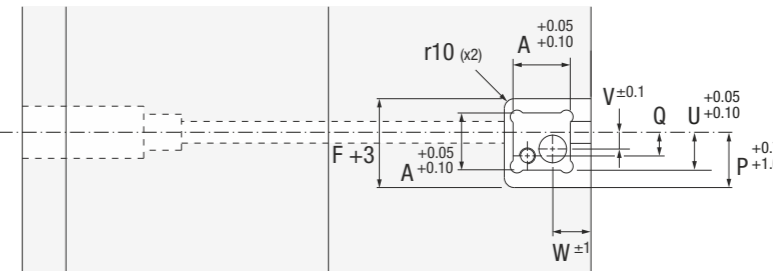
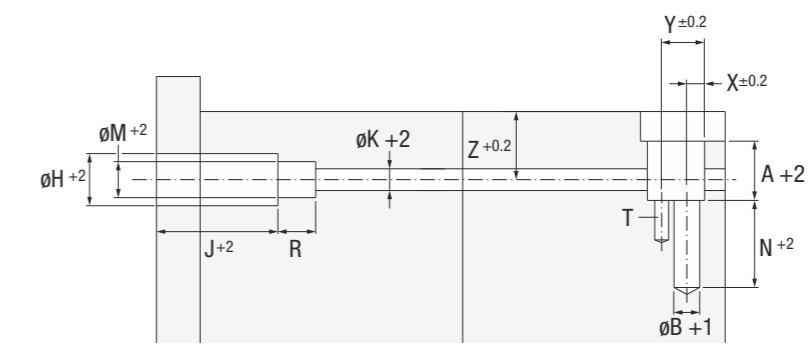

Cavity Housing

Alojamiento Placa Cavidad · Einbaumaße DR Führung · Sede piastra cavità · Alojamento na Cavidade · Logement dans l'empreinte

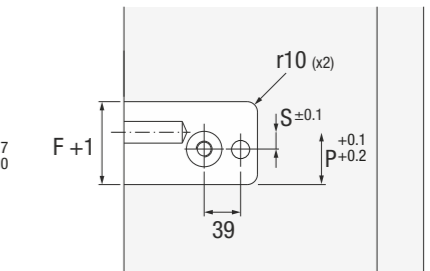
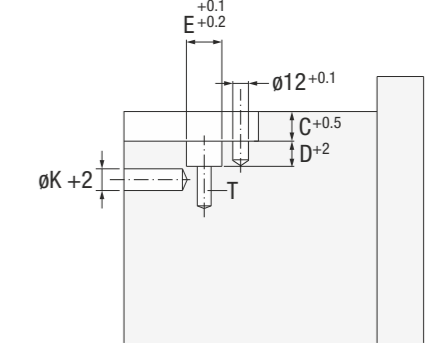

Installation Guidelines

Consejos de Instalación · Richtlinien zur Installation · Consigli di Installazione · Instruções de Instalação · Mode d'Installation

