

LONG STROKE FOR SLIDES

ES Corredera de Largo Recorrido DE Langhubschieber

IT Carrelli a Lunga Corsa PT Elemento Móvel de Longo Curso FR Coulisseau pour Courses Longues

LS

SLIDES



Patented

Max. 200°C

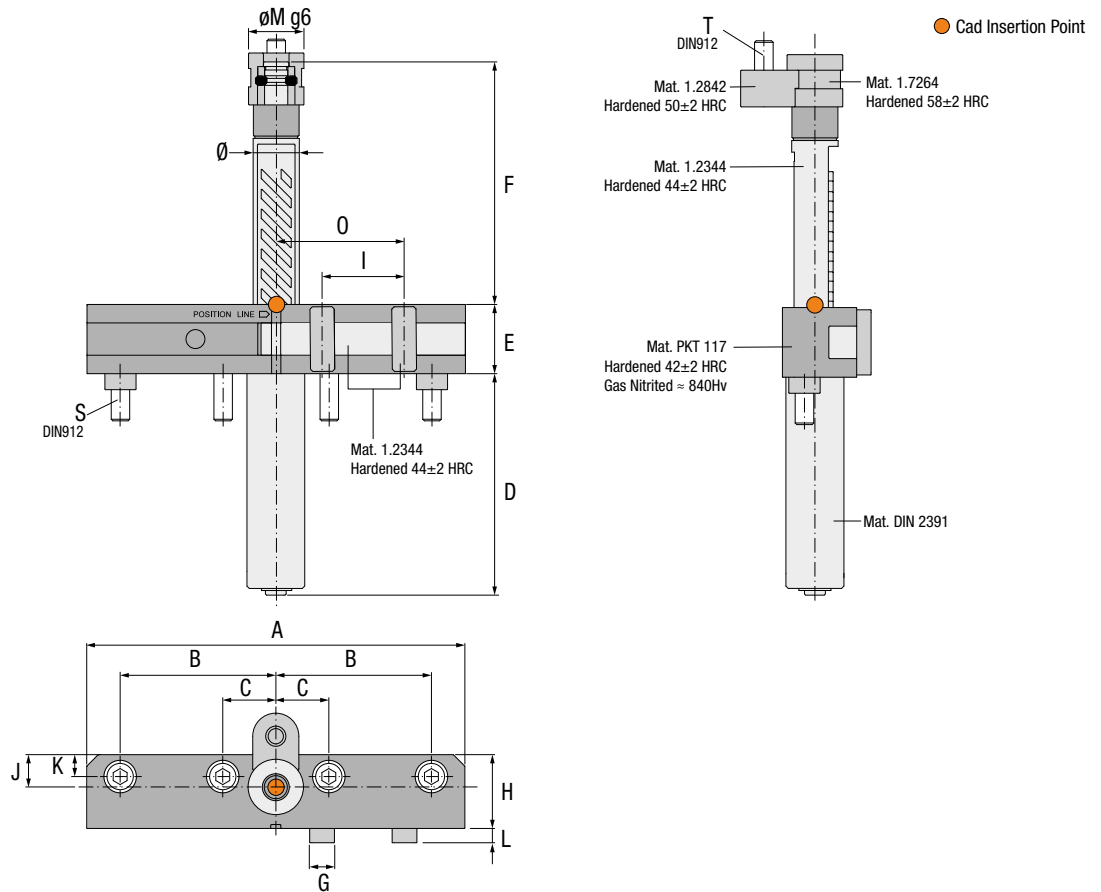

Ref.	Mirror Ref. -S	Ø	Stroke	A	B	C	D	E	F	G	H	I	J	K	L	M	N	O	P	Q	R	S
LS.20050L	LS.20050L-S	20	50	114	47.5	-	69	30	80	10.5	32	-	14	9.5	6.2	24	8	30	25	26	13.5	M8x45
LS.20075L	LS.20075L-S	20	75	164	67.5	23	94	30	105	10.5	32	35.5	14	9.5	6.2	24	8	55	25	26	13.5	M8x45
LS.20100L	LS.20100L-S	20	100	214	92.5	30	119	30	130	10.5	32	60.5	14	9.5	6.2	24	8	80	25	26	13.5	M8x45
LS.30050L	LS.30050L-S	30	50	126	50	-	72	48	89	16	48	-	20.5	13	10.2	36	12	25	35	36	18.5	M12x65
LS.30075L	LS.30075L-S	30	75	176	58	-	97	48	114	16	48	-	20.5	13	10.2	36	12	50	35	36	18.5	M12x65
LS.30100L	LS.30100L-S	30	100	226	100	46	122	48	139	16	48	50.5	20.5	13	10.2	36	12	75	35	36	18.5	M12x65

Semi-standard Ref.	Mirror Ref. -S	Stroke (multiples of 5mm.)		D	F	A1	A2	A3	Other dimension equal to
		Min.	Max.						
LS20-SP0	LS20-SP0-S	5	45	Stroke +19	Stroke + 30	-	-	-	LS.20050L
LS20-SP1	LS20-SP1-S	55	70	Stroke + 19	Stroke + 30	Stroke - 50	12	22	LS.20050L
LS20-SP2	LS20-SP2-S	80	95	Stroke + 19	Stroke + 30	Stroke - 75	12	22	LS.20075L
LS20-SP3	LS20-SP3-S	105	150	Stroke + 19	Stroke + 30	Stroke - 100	12	22	LS.20100L
LS30-SP0	LS30-SP0-S	5	45	Stroke + 22	Stroke + 39	-	-	-	LS.30050L
LS30-SP1	LS30-SP1-S	55	70	Stroke + 22	Stroke + 39	Stroke - 50	18	35	LS.30050L
LS30-SP2	LS30-SP2-S	80	95	Stroke + 22	Stroke + 39	Stroke - 75	18	35	LS.30075L
LS30-SP3	LS30-SP3-S	105	150	Stroke + 22	Stroke + 39	Stroke - 100	18	35	LS.30100L

EXAMPLE

LS20-SP3
Stroke = 125

D	F	A1
125	125	125
+	+	-
19	30	100
=	=	=
144	155	25

IMPORTANT!

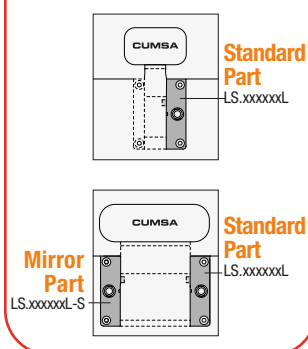

Angle Options

Opciones de Ángulo · Winkel-Optionen · Opzioni angolari · Opções de ângulo · Options d'angle

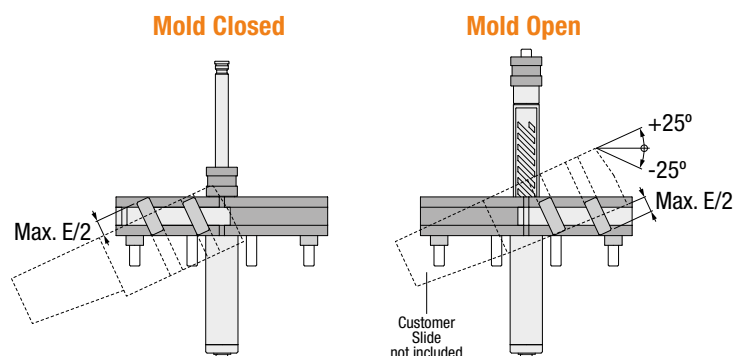

INSTALLATION GUIDELINES

ES Consejos de Instalación DE Richtlinien zur Installation
 IT Consigli di Installazione PT Instruções de Instalação FR Mode d'Installation

Core Housing

Alojamiento Placa Punzón · Einbaumaße PB Führung · Sede nel Punzone · Alojamento Bucha · Logement dans l'empreinte

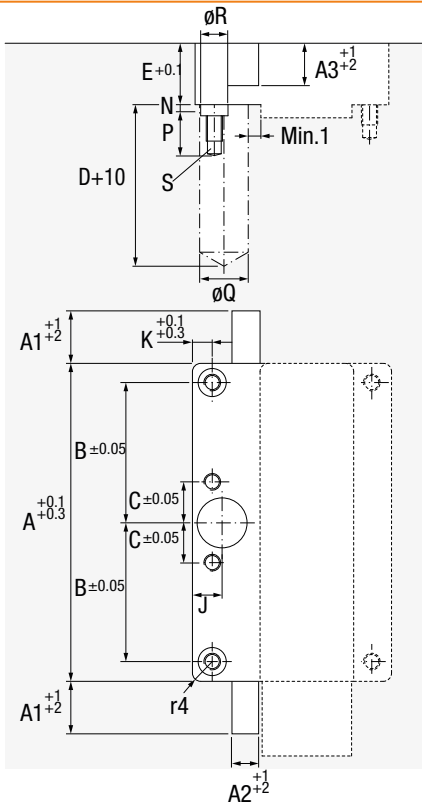

Cavity Housing

Alojamiento Placa Cavidad · Einbaumaße DR Führung · Sede piastra cavità · Alojamento na Cavidade · Logement dans l'empreinte

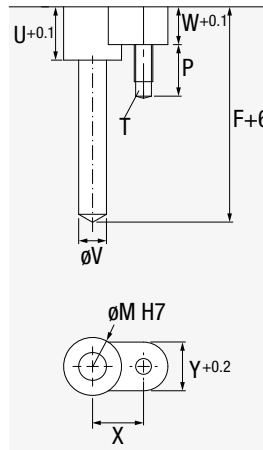

LS

SLIDES

Patented



	T	U	V	W	X	Y	Z
M8x20	23	12	16.3	22	20	10.7	
M8x20	23	12	16.3	22	20	10.7	
M8x20	23	12	16.3	22	20	10.7	
M12x30	27.5	20	20.5	33	24	12.7	
M12x30	27.5	20	20.5	33	24	12.7	
M12x30	27.5	20	20.5	33	24	12.7	

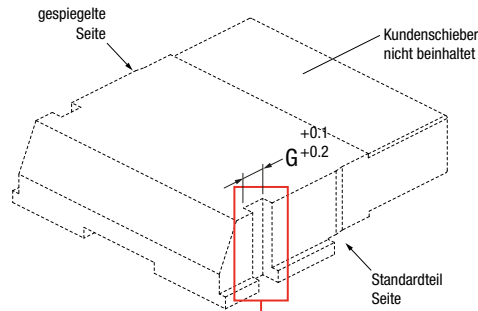

IMPORTANT !
 LS groove connection.
 Regata para la conexión con el LS.
 LS-Nutverbindung.
 Scanalatura di connessione con l'LS.
 Caixa de encaixe para o LS.
 Rainure pour la connexion avec le LS.

Installation Guidelines

Consejos de Instalación · Richtlinien zur Installation · Consigli di Installazione · Instruções de Instalação · Mode d'Installation

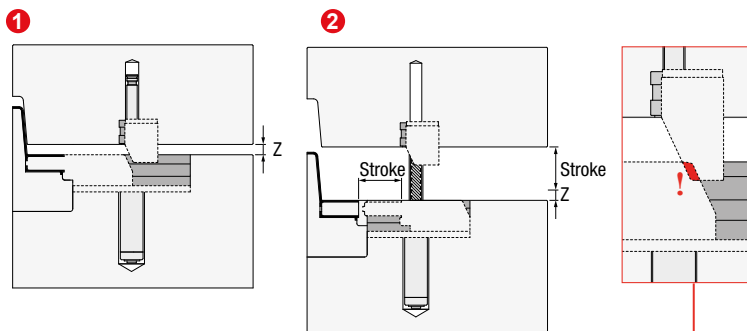

IMPORTANT !
 Check heel unit and slide angles to avoid interferences.
 Verifique los ángulos de la cuña y la corredera para evitar interferencias.
 Bitte prüfen den Sitz der Verriegelung zu dem Schieber mit dem Winkel um eine Beeinträchtigung zu vermeiden.
 Verificare il contrasto guida e l'angolo del carrello per evitare interferenze.
 Verifique angulos de ajuste do bloco de encosto para evitar colisões.
 Vérifier les angles des cales et des coulisseau pour éviter les interférences.

