

# CUMSA

INNOVATIVE SOLUTIONS  
FOR YOUR MOLDS

## SWAP MOLD VERSION FASTER



DIRECTLY THROUGH THE PARTING LINE

ACCESSORIES

EN

# GREAT ADVANTAGES



## EASY & FAST

Minimize mold manipulation, simplify maintenance and reduce production downtime.



## PARTING LINE APPROVED

Avoid losing time when changing different mold designs, compromising production time and workers' safety.



## AIR-SWAP SYSTEM

Simply apply air to the channel to switch the insert, no need to disassemble the mold or use any tools! (system operates between 6-8 BAR).



## NEXT GENERATION REVOLUTION

Modular, multi-application solution that outperforms traditional methods, available in two sizes.



## HIGH PRECISION AND ADAPTABILITY

Adjustable height ensures uniform, smooth results without variations every time.



## MAXIMIZED EFFICIENCY & COST SAVINGS

Convert mold change time into increased production swap inserts in under a minute.

# IC

## INSERT CHANGER

ES Intercambiador de Postizos DE Einsatzwechsler IT Dispositivo Cambia-Inserto  
PT Postiço Intermutável FR Échangeur d'Inserts

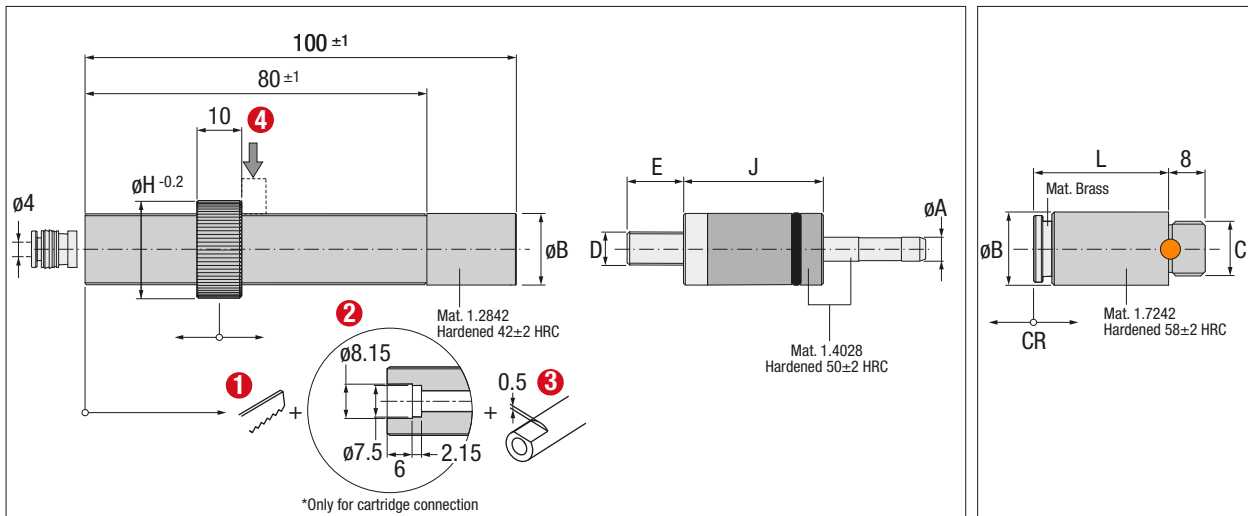

Min. 6 BARS  
Max. 8 BARS

Ref.	A	B	D	E	H	J
IC.040100	4	12	M6x0.75	9.5	18	25
IC.120100	12	20	M10x0.75	12	26	27

Ref.	C	L	CR (N)
IC.041208	M8x0.75	32.3	≥ 1.800
IC.122018	M18x1	30	≥ 7.600

### Insert Change Process

Proceso cambio de inserto · Einsatzwechselfvorgang · Procedura per cambio inserto · Processo de troca de postiço · Processus de changement d'inserts

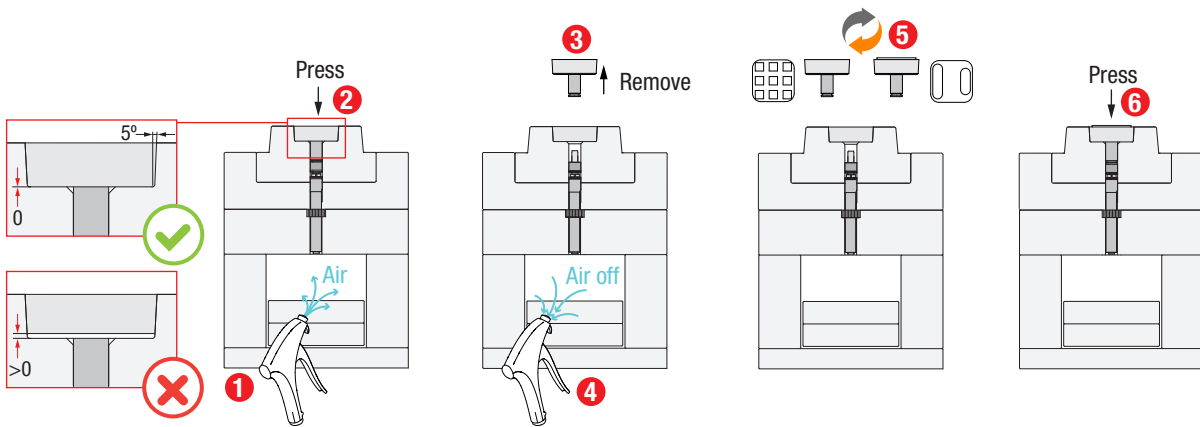

### Installation Options

Opciones de Instalación · Optionen zur Installation · Opzioni di Installazione · Opções de Instalação · Options d'Installation

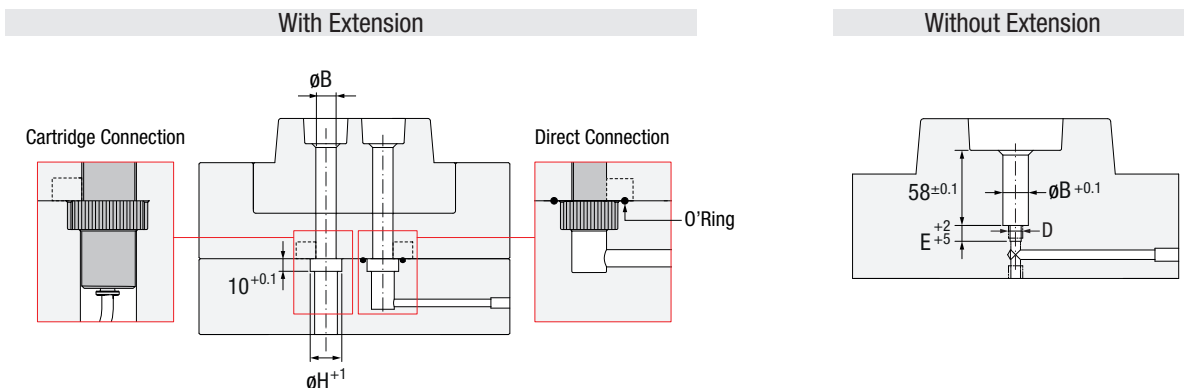

# CUMSA

[www.cumsa.com](http://www.cumsa.com)

Ed. 2025 - 11

Isaac Peral, 21  
08960 · Sant Just Desvern  
Barcelona · Spain  
Tel: +34 93 473 25 52  
Fax: +34 93 473 49 19  
e-mail: [info@cumsa.com](mailto:info@cumsa.com)



The future  
**IS HERE**



**CUMSA**  
— USA —

Tel.: +1 248 850 8385  
e-mail: [info@cumsausa.com](mailto:info@cumsausa.com)

**EURO**  
**CUMSA**

Tel.: +351 244 770 420  
e-mail: [geral@eurocumsa.pt](mailto:geral@eurocumsa.pt)

**CUMSA**  
— ITALIA —

Tel.: +39 (0) 362 170 8735  
e-mail: [cumsaitalia@cumsa.com](mailto:cumsaitalia@cumsa.com)

**CUMSA**  
— 坤盛 中国 —

Tel.: +86 755 2998 5783  
e-mail: [cumsachina@cumsa.com](mailto:cumsachina@cumsa.com)

**CUMSA**  
— DEUTSCHLAND —

Tel.: +49 (0) 160 2611 003  
e-mail: [deutschland@cumsa.com](mailto:deutschland@cumsa.com)

**CUMSA ASIA PACIFIC Ltd.**  
Tel.: +86 755 2823 6174

**NEED HELP INCORPORATING CUMSA PRODUCTS?**

Contact our team at [technical@cumsa.com](mailto:technical@cumsa.com) for a free project consultation.

