

MULTIPLE SOLUTIONS FOR YOUR PLATE MOVEMENTS

THREE PLATE MOLD:

Products designed to make a pre-opening movement in the mold cavity, before opening the mold to eject the part.

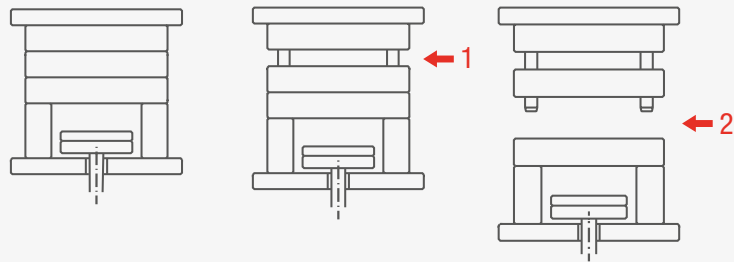

LEADING DOUBLE EJECTION:

Double ejection system to control 2 sets of ejector plates when the injection machine actuates the upper set of ejector plates.

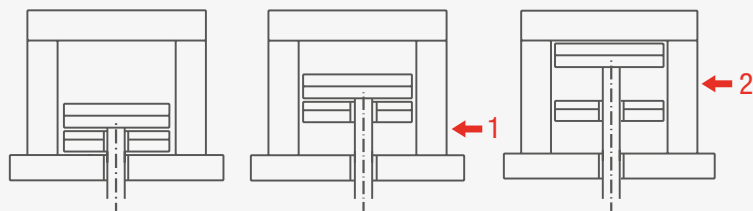

TRAILING DOUBLE EJECTION:

Double ejection system to control 2 sets of ejector plates when the injection machine actuates the lower set of ejector plates.

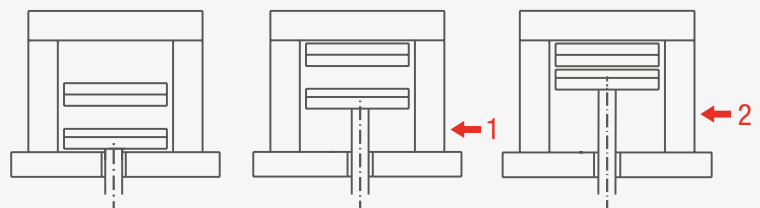

SYNCHRONIZED PLATES:

Designed to allow synchronized mold plates openings, regardless of their location. With a customizable first stroke opening, and a free second movement.

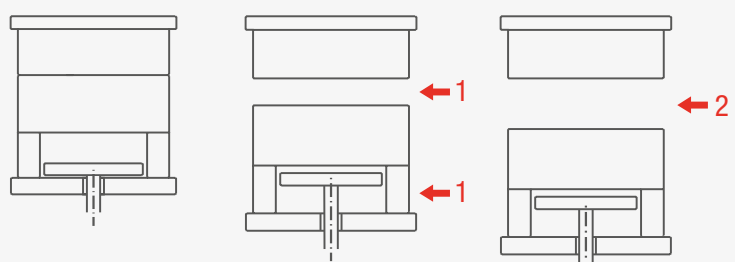

COMPACT DOUBLE EJECTION

ES Doble Expulsión Compacta DE Kompakter Zweistufenauswerfer
 IT Doppia Espulsione Compatta PT Dupla Extração Compacta FR Double Ejection Compact



SY

● Cad Insertion Point

Ref.
 SY.327054

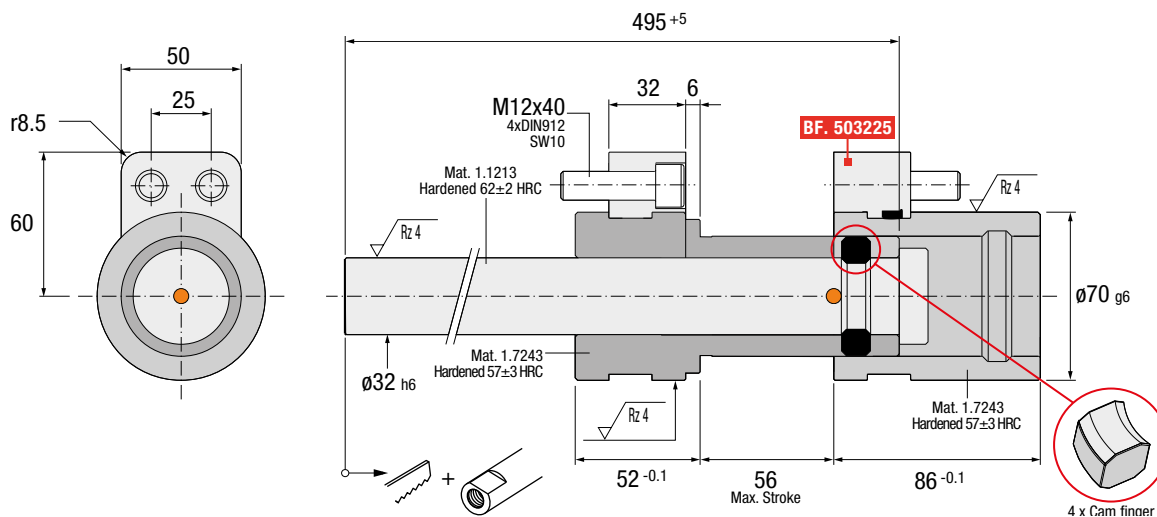

Patented
 Max. 150°C

IMPORTANT !

2 BF.503225 units included. More units can be ordered separately.
 Se suministran 2 unidades de BF.503225. Se pueden pedir más unidades por separado.
 2 St. BF.503225 enthalten. Mehr Einheiten können einzeln bestellt werden.
 Vengono forniti 2 BF.503225. E' possibile ordinarne altri separatamente.
 2 unidades BF.503225 incluídas. Possibilidade de encomendar mais unidades individualmente.
 2 unités BF.503225 incluses. Possibilitée de commander à la pièce.

Installation Guidelines

Consejos de Instalación · Richtlinien zur Installation · Consigli di Installazione · Instruções de Instalação · Mode d'Installation

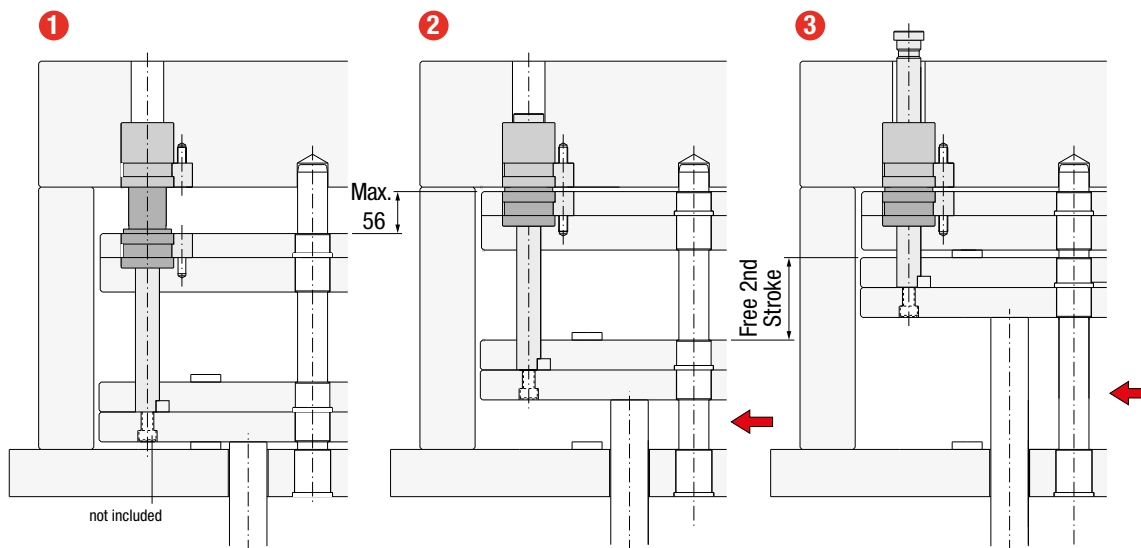

IMPORTANT !

