

# PLATE RETAINER

ES Retenedor Placas DE Platten Verriegelung  
 IT Ritensores Piastra PT Retensor de Placa FR Tire Plaques



PR

● Cad Insertion Point

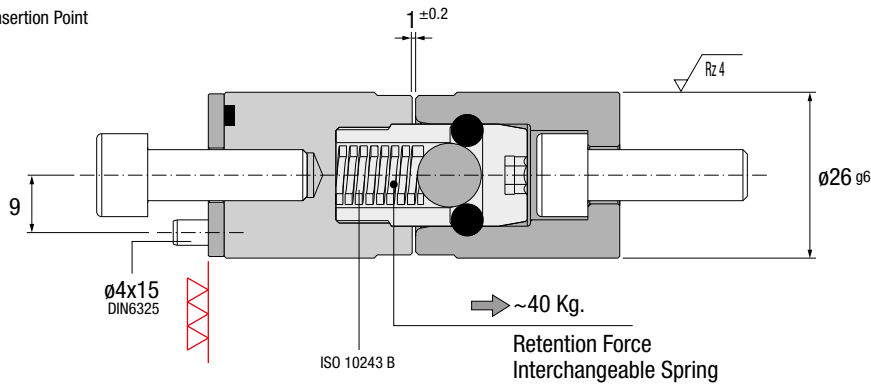

Ref.  
PR.263230

Max.  
150°C

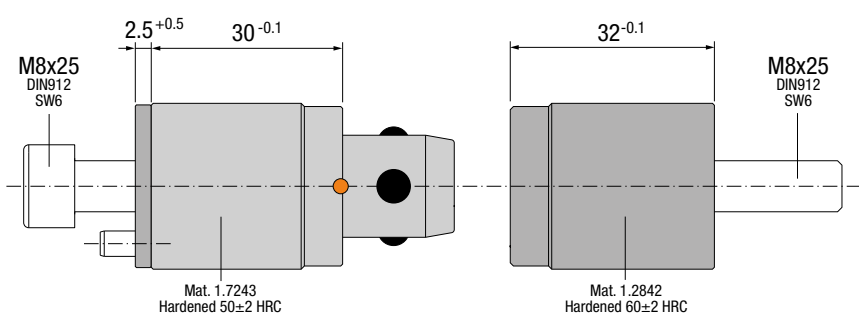

# STROKE LIMITER

ES Limitador de Recorrido DE Hubbegrenzer  
 IT Limitatore Apertura PT Limitador de Curso FR Limiteur de Course



SL

● Cad Insertion Point

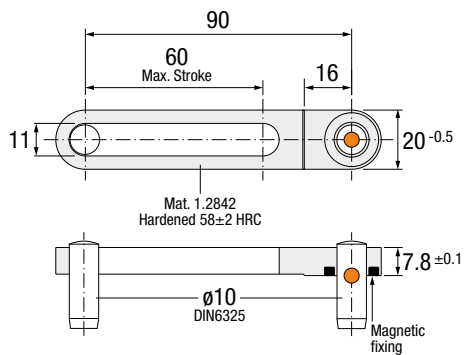

Ref.  
SL.602008

**IMPORTANT!**  
 Possibility to reduce the max. opening (60mm.).  
 Posibilidad de reducir la apertura máxima (60mm.).  
 Der maximale Öffnungshub kann verringert werden (60mm).  
 Rende possibile ridurre l'apertura massima a 60mm.  
 Possibilidade de reduzir a abertura max. (60mm).  
 Possibilité de réduire la course (maxi 60mm).

## Installation Guidelines

Consejos de Instalación · Richtlinien zur Installation · Consigli di Installazione · Instruções de Instalação · Mode d'Installation

Max.  
150°C

