

REFERENCE	A
SME110	110
SME170	170
SME245	245
SME 110-250	250
SME110-300	300
SME110-350	350
SME110-400	400
SME110-450	450

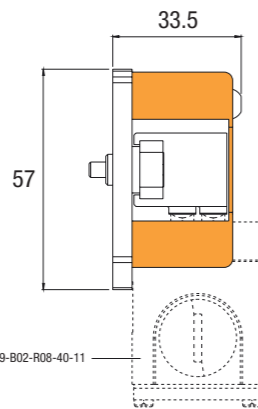
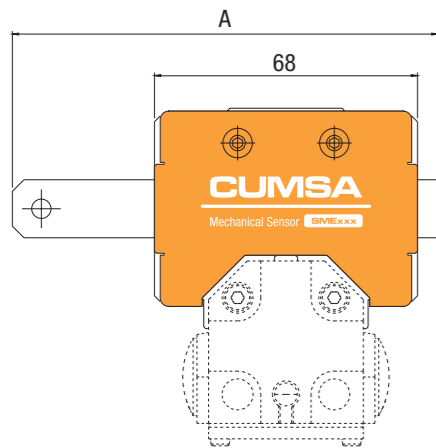

Recommended
Balluff® part# BNS 819-B02-R08-40-11
NOT INCLUDED

IMPORTANT

Left / Right Assembling options
Opción de instalación derecha / izquierda
Montagemöglichkeiten links/rechts
Opzioni di montaggio sinistra / destra
Opção de montagem Esquerdo / Direito
Option de montage Gauche / Droite

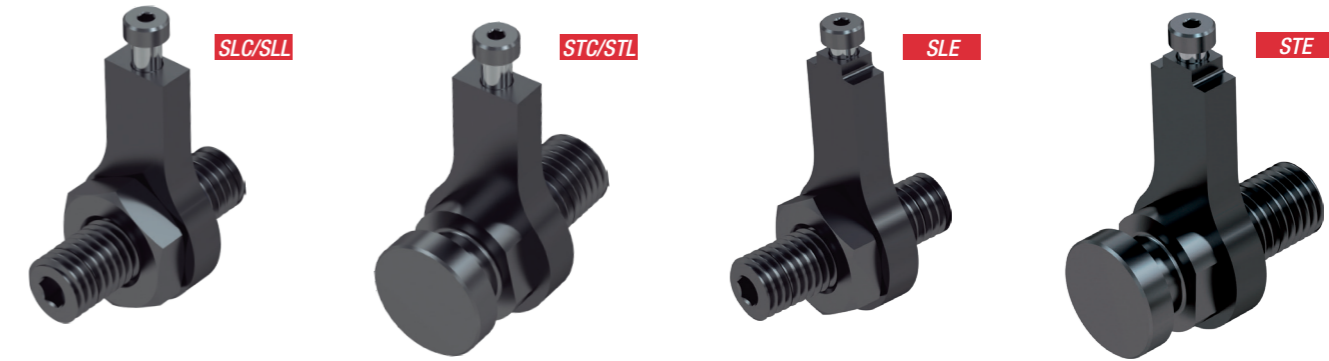

REFERENCE For Cylinders A-B	Ø PISTON	FOR FACE	REFERENCE For Cylinders E
SLC016	16	1 & 3	
SLC025	25	1 & 3	SLE025 STE025
SLC032	32	1 & 3	SLE032 STE032
SLC040	40	1 & 3	SLE040 STE040
SLC050	50	1 & 3	SLE050 STE050
SLC063	63	1 & 3	SLE063 STE050
SLC080	80	1 & 3	
SLL025	25	2 & 4	
SLL032	32	2 & 4	
SLL040	40	2 & 4	
SLL050	50	2 & 4	
SLL063	63	2 & 4	
SLL080	80	2 & 4	

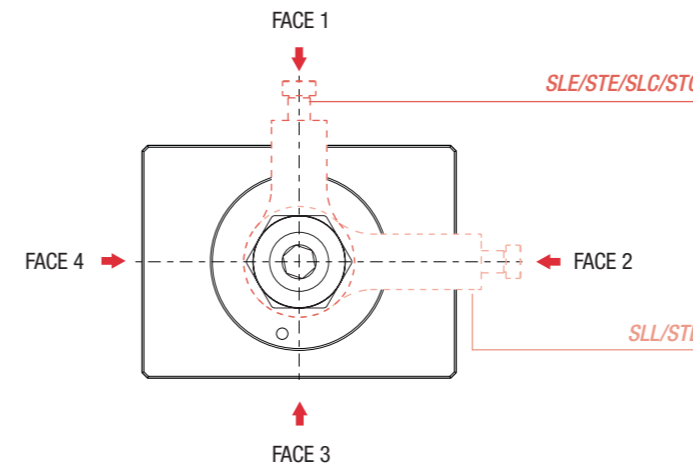

SENSOR REFERENCE BY STROKE / REFERENCIA DE SENSOR POR RECORRIDO / SENSORPREFERENZ VOM HUB / REFERENZA SENSORE PER CORSA / REFERÊNCIA DO SENSOR POR CURSO / RÉFÉRENCE DU DÉTECTEUR PAR COURSE

FOR MODEL	STROKE	Ø 16	Ø 25	Ø 32	Ø 40	Ø 50	Ø 63	Ø 80	Ø 100
A · B	10	SME110	SME110	SME110					
A · B	20	SME110	SME110	SME110	SME110	SME110	SME110		
A · B	30	SME110	SME110	SME110	SME110	SME110	SME110		
A · B	40	SME110	SME110	SME170	SME170	SME170	SME170		
A · B	50	SME170	SME170	SME170	SME170	SME170	SME170		
A · B	60	SME170	SME170	SME170	SME170	SME170	SME170		
A · B	70	SME170	SME170	SME170	SME170	SME170	SME170		
A · B	80	SME170	SME170	SME170	SME170	SME170	SME170	SME170	SME170
A · B	90	SME170	SME170	SME170	SME170	SME170	SME170	SME170	SME170
A · B	100	SME170	SME170	SME245	SME245	SME245	SME245	SME245	SME245
A · B	110		SME245	SME245	SME245	SME245	SME245	SME245	SME245
A · B	120		SME245	SME245	SME245	SME245	SME245	SME245	SME245
A · B	130			SME245	SME245	SME245	SME245	SME245	SME245
A · B	140			SME245	SME245	SME245	SME245	SME245	SME245
A · B	150			SME245	SME245	SME245	SME245	SME245	SME245
A · B	160				SME245	SME245	SME245	SME245	SME245
A · B	170					SME245	SME245	SME245	SME245
A · B	180					SME245	SME245	SME245	SME245
E	100-200		SME110-250	SME110-250	SME110-250	SME110-250	SME110-250		
E	201-250		SME110-300	SME110-300	SME110-300	SME110-300	SME110-300		
E	251-300		SME110-350	SME110-350	SME110-350	SME110-350	SME110-350		
E	301-350		SME110-400	SME110-400	SME110-400	SME110-400	SME110-400		
E	351-400		SME110-450	SME110-450	SME110-450	SME110-450	SME110-450		

FACE SENSOR POSITIONS BY FIXING STYLE / FACE DE POSICIÓN DEL SENSOR POR ESTILO DE FIJACIÓN / FLÄCHE SENSORPOSITION DER BEFESTIGUNGSART / FACE DI POSIZIONE DEL SENSORE PER TIPO DI FISSAGGIO / FACE DE POSIÇÃO DO SENSOR, CONFORME MODO DE FIXAÇÃO / FACE DE POSITION DU DÉTECTEUR, CONFORME AU MODE DE FIXATION

For cylinders A-B-E

FIXING STYLE	CW				FW				DW				EW				AW				AX				DX				AY				EY				CZ				FZ				CV			
	1	2	3	4	1	2	3	4	1	2	3	4	1	2	3	4	1	2	3	4	1	2	3	4	1	2	3	4	1	2	3	4	1	2	3	4	1	2	3	4	1	2	3	4				
Face 16	●	-	-	-	●	-	-	-	●	-	-	-	●	-	-	-	●	-	-	-	●	-	-	-	●	-	-	-	●	-	-	-	●	-	-	-												
Face 25	●	-	-	-	●	-	-	-	●	-	-	-	●	-	-	-	●	-	-	-	●	-	-	-	●	-	-	-	●	-	-	-	●	-	-	-												
Face 32	●	●	●	●	●	●	●	●	●	●	●	●	●	●	●	●	●	●	●	●	●	●	●	●	●	●	●	●	●	●	●	●	●	●	●	●												
Face 40	●	●	●	●	●	●	●	●	●	●	●	●	●	●	●	●	●	●	●	●	●	●	●	●	●	●	●	●	●	●	●	●	●	●	●	●												
Face 50	●	●	●	●	●	●	●	●	●	●	●	●	●	●	●	●	●	●	●	●	●	●	●	●	●	●	●	●	●	●	●	●	●	●	●	●												
Face 63	●	●	●	●	●	●	●	●	●	●	●	●	●	●	●	●	●	●	●	●	●	●	●	●	●	●	●	●	●	●	●	●	●	●	●	●												
Face 80	●	●	●	●	●	●	●	●	●	●	●	●	●	●	●	●	●	●	●	●	●	●	●	●	●	●	●	●	●	●	●	●	●	●	●	●												
Face 100	●	●	●	●	●	●	●	●	●	●	●	●	●	●	●	●	●	●	●	●	●	●	●	●	●	●	●	●	●	●	●	●	●	●	●	●												