

# SLIDE RETAINER

ES Retenedor Corredera DE Schiebersicherung  
 IT Retensore Carrello PT Retensor de Corrediças FR Blocage de Coulisseau



# RCM

● Cad Insertion Point

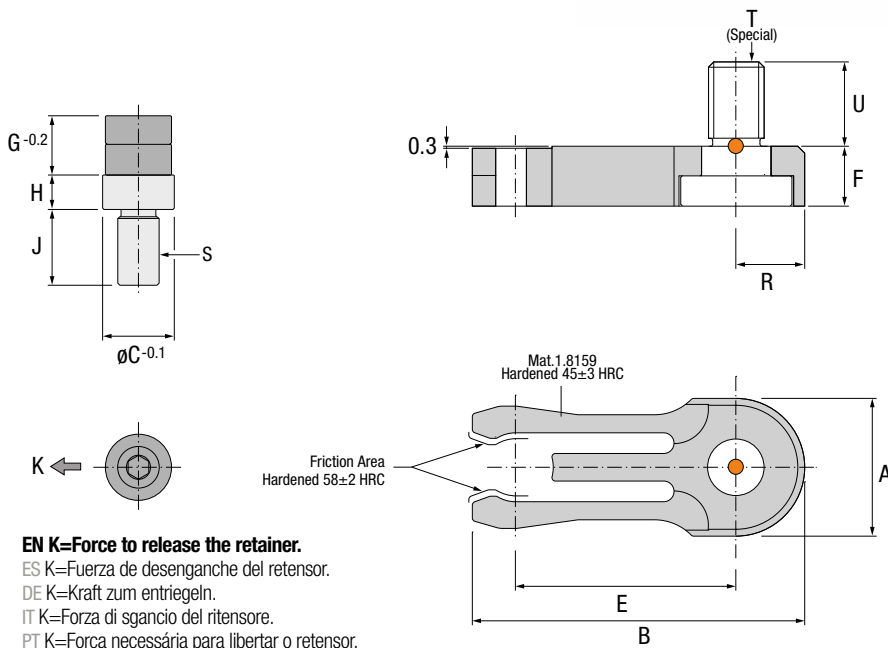

**EN K=Force to release the retainer.**  
 ES K=Fuerza de desenganche del retensor.  
 DE K=Kraft zum entriegeln.  
 IT K=Forza di sgancio del ritenore.  
 PT K=Força necessária para libertar o retensor.  
 FR K=Force de libération de la retenue.

Ref.	A	B	C	E	F	G	H	J	K	N	R	S	T	U
RCM.163808	16	38	8	25	7.6	7.6	4	10	10 kg.	7	8	M5	M6	9
RCM.204810	20	48	10	32	8.7	8.6	5	11	14 kg.	8	10	M6	M8	12
RCM.245712	24	57	12	37.5	9.6	9.6	6	12	18 kg.	9	12	M8	M10	15

## Installation Guidelines

Consejos de Instalación · Richtlinien zur Installation · Consigli di Installazione · Instruções de Instalação · Mode d'Installation

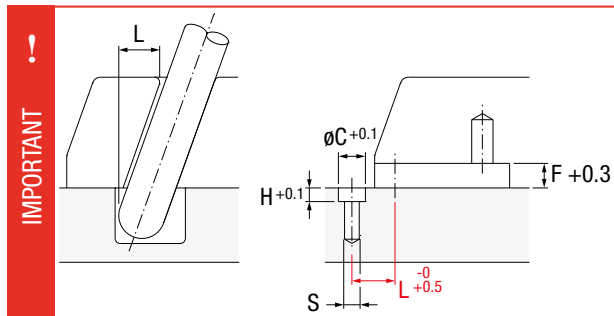

### Slide Disassembling

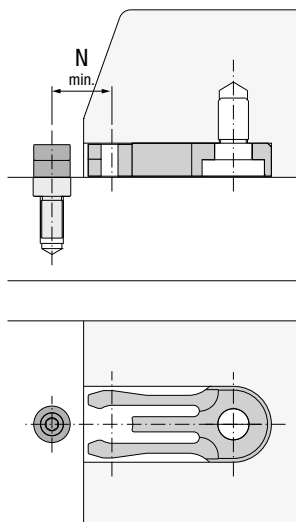

### Mold Open

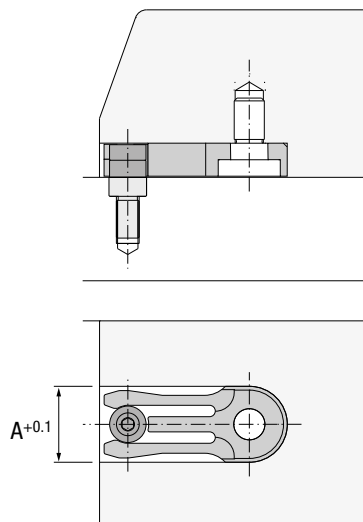

Patented

