



SLIDE RETAINER

ES Retenedor Corredera DE Schiebersicherung
 IT Ritenore Carrello PT Retensor de Corrediças FR Blocage de Coulisseau

● Cad Insertion Point

RC

Patented

Max. 150°C

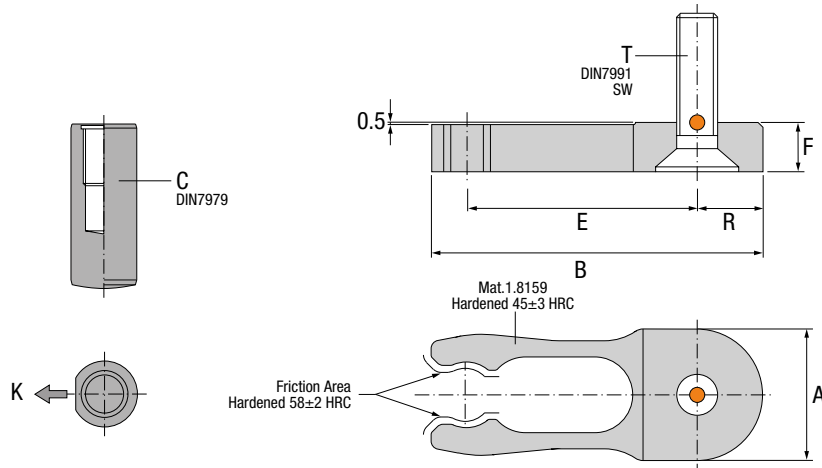

EN K=Force to release the retainer.

ES K=Fuerza de desenganche del retensor.
 DE K=Kraft zum entriegeln.
 IT K=Forza di sgancio del ritenore.
 PT K=Força necessária para libertar o retensor.
 FR K=Force de libération de la retenue.

Ref.	A	B	C	E	F	G	H	K	R	T	SW
RC.123006	12	30	6x20	21	4.7	4	16	5 kg.	6	M5x16	3
RC.164008	16	40	8x20	28	5.7	5	15	7 kg.	8	M6x20	4
RC.205010	20	50	10x24	34	7.7	6	17	14 kg.	10	M8x25	5
RC.246012	24	60	12x32	42	9.7	7	23	21 kg.	12	M10x30	6
RC.328012	32	80	16x40	56	11.7	9	27	28 kg.	16	M12x35	8
RC.328016	32	80	16x40	56	15.7	9	25	38 kg.	16	M12x50	8

OPTIONAL DOWEL PIN

ES Pasador Opcional DE Zylinderstift (Optional)
 IT Riferimento Opzionale PT Cavilha Opcional FR Goupille Optionnel

● Cad Insertion Point

PO

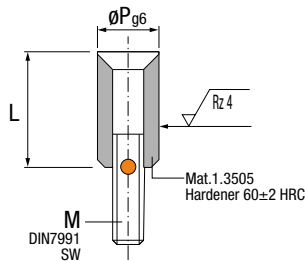

Ref.	L	M	N	P	SWa
P0.120320	12	M3x20	7.5	6	2
P0.150425	15	M4x25	10	8	2.5
P0.200530	20	M5x30	13	10	3
P0.250635	25	M6x35	16	12	4
P0.340850	34	M8x50	23	16	5

Installation Guidelines

Consejos de Instalación · Richtlinien zur Installation · Consigli di Installazione · Instruções de Instalação · Mode d'Installation

Patented
 Max. 150°C

